



PASC4 Catalog

Computer Room Air Conditioner
50/60 Hz - SI/IMP

www.petra-eng.com



These marks apply to different products manufactured by Petra Engineering Industries Co. The inclusion of these marks does not mean they apply to all the products within this publication

Petra Computer Room Split Air Conditioning Unit
with Hermetic Scroll Compressors and R-410A Refrigerant

13 - 73 Nominal kW
(45 - 250 Nominal MBH)



Table of Contents

Introduction	2
Outstanding Features	3
Nomenclature	3
Unit Types	4
Standard Features - Indoor Unit	5
Standard Features - Outdoor Unit	8
Optional Features	9
Computer Room Air Handling Unit - Optional	10
Microprocessor Controller	11
Sequence of Control	12
Graphical Touch Screen (Optional)	14
Smart Watch Solution (Optional)	14
Physical Data	18
Model Layout	24
Unit Clearance	30
Selection Procedure	31
Performance Data	32
Refrigeration Schematic Piping	36
Electrical Data	38
Wiring Diagram	40

Introduction



Petra Engineering Industries Company is a highly established HVAC manufacturing company that produces a wide range of sophisticated, high quality commercial and industrial HVAC equipment. Petra's products meet the requirements of globally recognized standards and procedures

To ensure the highest level of quality all procedures are carried out according to ISO 9001:2015 Quality management systems and ISO14001:2015 environmental management system. Also, all Petra's major products are UL, ETL listed. Petra Computer room air conditioners are rated and certified in compliance to standard AHRI 1360.

Petra understands the importance of environmental control for sensitive equipment and offers its Computer Room Split Air Conditioner "PASC4" series. PASC4 Series is specifically designed to be used wherever temperature, humidity and filtered air have to be controlled continuously within close tolerance limits

Sensitive Electronic devices require demanding & controllable environment throughout the year (24/7).

Such devices have to be controlled in terms of humidity and internal temperature to close tolerance limits. Typical requirements of such environment is to maintain internal conditions between 16-28 °C (60.8-82.4 °F) with moisture content of 50-60% relative humidity

Computers & communications systems generate 6-10 times the heat load of normal occupied spaces and they require state of art air conditioning equipment to control them

They can be installed in data centers, tele-communications centers, laboratories, computer server data rooms, network operation centers, testing facilities and others

Outstanding Features



Why to Choose Petra

Petra PASC4 has been developed and based on proven design and in house testing according to the highest international standards. It is used in various of systems all over the world. Petra PASC4 provides the highest energy efficiency both at operating & running conditions and thus provides the lowest operating cost. This is achieved by using the most reliable and energy efficient electronic components. Savings are obtained by using optional digital scroll compressor, EC fan motors, external rotor condenser fans and Petra piece of art microprocessor controller

Reliability

Unmatched corrosion resistance with oven baked powder coat (5,000 hours salt spray test) the highest in industry. Microprocessor controller built to space requirements with intelligent alarm and diagnostic system that can prevent a problem before it occurs. Full refrigerant system control with air delivery variation to deliver the specific space load requirements with the lowest energy consumption ever

Flexibility

Down flow and up flow configurations are available to suit a wide range of rooms applications. Different choice of compressors from on/off or digital to match space performance with optimal efficiency. Front access panel for service and maintenance that saves floor space. Front access using hinged doors, allows Petra PASC4 to be mounted against a wall or partitions on adjacent to or back at other equipment. All unit component are accessible from the front panels for maintenance or replacement

Built-in humidity and reheat devices. Ozone friendly refrigerants (R-407c & R-410A). Full microprocessor control panel with different BMS connectivities and full diagnostic system

Optional CHW Coil

Computer rooms can be supplied with a chilled water coil to make a high precision air handling unit that can be connected to outdoor chilled water system

Nomenclature

Example:

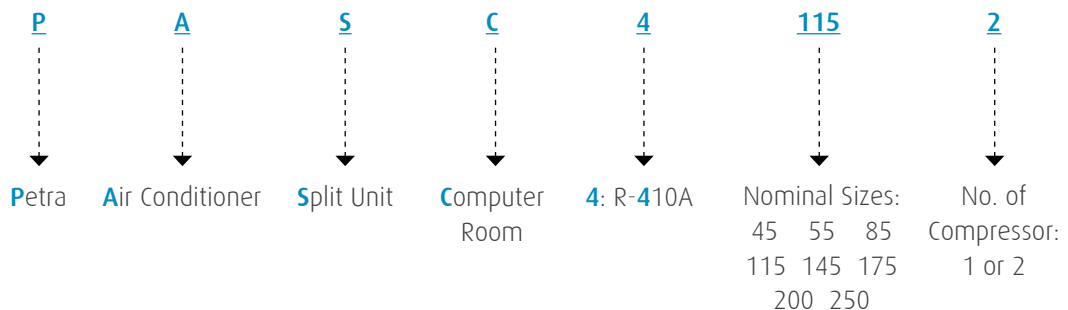

Unit Types



Up Flow - (PASC4 35-1 ~ 85-2)

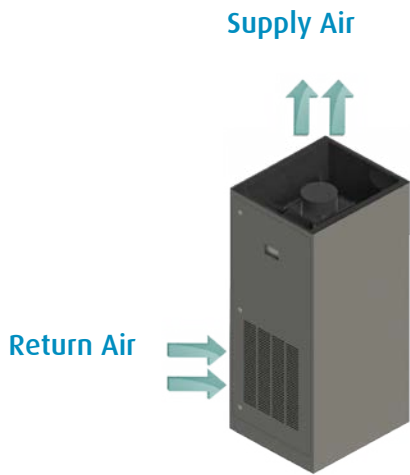

Up Flow - (PASC4 115-2 ~ 250-2)

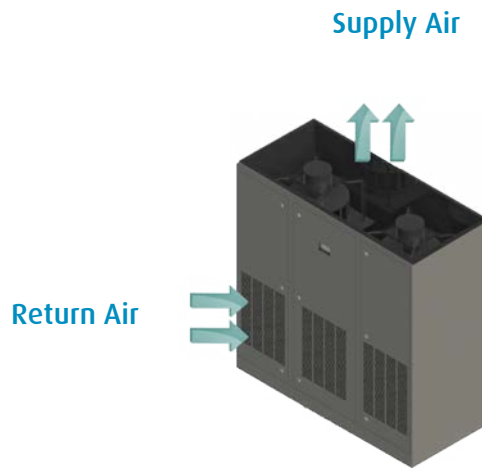

Down Flow - (PASC4 35-1 ~ 85-2)



Down Flow - (PASC4 115-2 ~ 250-2)

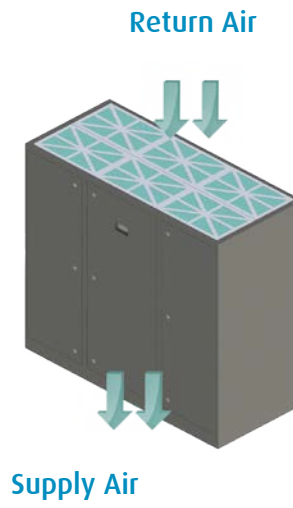

Air Cooled Remote Condenser



Standard Features - Indoor Unit



Construction

- All units are constructed of heavy gauge galvanized steel
- The entire unit exterior/interior is painted with polyester powder electrostatic coat, oven baked with unmatched corrosion resistance up to 5,000 hour salt bath test in accordance to ASTM 117a and ASTM 117b
- Standard paint is RAL 9005 (Black)
- Double skin construction panels that are internally lined with 25 mm (1.0 inch) fiberglass insulation with 48 kg/m³ (3 lb/ft³) density or equivalent

Compressor

- Suction gas-cooled hermetic scroll compressor with low sound and superior efficiency
- Robust design of a three Teflon impregnated bearings and integral cast-iron housing for better compressor alignment
- IP 54 enclosure class of terminal box
- Scroll inherent durability with few moving parts and low motor strains
- Spiral surfaces wear in due to unique compliant design
- Mounted on a rubber-in-shear (RIS) vibration isolators
- Equipped with operating oil charge, crank case heater, crank case inherent solid state motor protector, suction strainer and short cycling delay timer protection
- Maximum operating compressor of 2,900 / 3,500 rpm (50/60 Hz)
- Minimized pressure losses with uniform gas compression in the scroll pockets at low velocities
- Minimized heat transfer losses because of a physical separation of suction and discharge gas
- Immediate internal pressure balancing (high side / low side) at shut-off
- High volumetric efficiency with no dead space design



Scroll Compressor

EC fan technology

- PASC4 series standard unit use EC fans to increase energy efficiency and provide supply fan technology control operation
- PASC4 series indoor units are powered by energy saving EC motors. The electronically controlled EC fan motor reacts steplessly through "the piece of art" unit controller to changing output requirements
- EC fan motors can run at partial loads in energy saving mode and are unaffected by voltage fluctuations
- EC fan motors consume up to 30% less energy than conventional fan/motor assemblies and provide variable speed control through a signal from unit controller
- EC fan motors characteristics:
 - Up to 92% motor efficiency, resulting in substantial lower operating cost
 - Quiet running, long life and maintenance free
 - Stepless load tracking to prevailing conditions



EC Fan

Standard Features - Indoor Unit



Coil

- Coils are manufactured from seamless copper tubes mechanically-expanded into aluminum fins to be suitable for working at 2,068 kPa (300 Psi) air pressure
- All coils are pressure tested at 6,200 kPa (900 Psi), under water to avoid leakage
- They also undergo dry chemical cleaning after manufacturing for optimum system cleanliness
- All coils are constructed from 9.5 mm (3/8 inch) tube diameter
- Stainless steel drain pan fitted under the coil



Coil

Filters

All models are provided with MERV 8, 50 mm (2.0 inch) nominal thickness pleated flat filter. Filters shall have an arrestance of 90-95% with equivalent European efficiency class of G4



Pleated Filter

Refrigeration components

- **Thermostatic expansion device:** This device controls the superheat of refrigerant vapor at the outlet of the evaporator
- **Filter Drier:** A filter drier is a very effective method for removing small amounts of moisture and contamination
- **Moisture sight glass indicator:** It provides a warning signal in the event that moisture has entered the system, indicating that the filter should be changed or that some action needs to be taken to effectively dry the system
- **Service charging nipple**
- **Liquid line shut off valve**
- **Liquid receiver**
- **Pressure switches:** High & low pressure switches are provided to protect the compressor and the refrigeration system from unsafe high and low pressure conditions
- **Solenoid valve:** Protection device for the compressor

Note

- Liquid line shut off valve & solenoid valve are standard refrigeration components for units that have compressors larger than 5hp only, for more details, please refer to refrigeration schematic diagrams pages 43-44

Electric heater

- Finned tube electrical heating elements with automatic or manual thermal safety cutout and contactors. Maintain the room's dry bulb temperature during the system dehumidification process

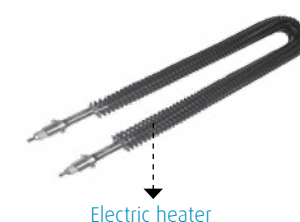

Electric heater

Air flow switch

- This device is used to provide protection in case of airflow failure. When the supply fan fails or when any resistance in the supply air is reducing the heat exchange with the electrical heaters, the controller will prevent the electrical heaters from continuing operation and the unit will trip



Air flow switch

Steam humidifier

- The steam humidifier is of the immersed electrode type and is controlled using highly advanced microprocessor technology. It is complete with a cleanable cylinder, drain valve, stainless steel distributor tube and electronic control



Steam humidifier

Silicon-controlled rectifier (SCR)

- SCR is a stepless controller for the electric heater to provide more precise control at the reheat mode to match space requirements. It eliminates overshoot and droop in reheating phase and ensures long heater life and better dehumidification performance with tighter control of room conditions
- Line voltage is switched 0-100% linearly, with respect to the input range
- This standard applies for PASC4 115-2 ~ PASC4 250-2 only



Silicon-controlled rectifier (SCR)

Voltage monitor controller (Phase failure relay)

- Used for monitoring the main incoming power supply to the unit and to provide protection for single phasing, under voltage, over voltage, phase-voltage imbalance and phase-nonsequence



Phase failure relay

Standard Features - Indoor Unit



Dirty filter switch

- This device is incorporated in the unit to provide an alarm in case of a dirty filter

Electrical components

- Compressor motor starting contactor
- Condenser fan motor starting contactor
- Control circuit breaker to protect the control circuit from short circuiting
- Control terminal strip for easy connection to the electrical board and easy field installation
- Humidity control electronic card
- Contactor for electrical re-heat coil
- Control transformer to supply microprocessor
- Steam humidifier starting contactor
- Flood detector for water under floor protection
- Time & date display

Standard Features - Outdoor Unit

Casing

Heavy gauge galvanized steel casing made from gauge 18 [1.2mm (0.05 inch)] coated with oven-baked, electro-static polyester powder paint with 5,000 hours salt spray protection



Air Cooled Remote Condenser

Condenser fans & motors

- Condenser fans shall be of the external rotor type
- Thermal contacts are fitted with external rotor motors
- Embedded deep in the windings of the motors, the contacts are bi-metal cutout design which are temperature-dependent. Should the temperature of the motor rise to the limit, the bi-metal cutouts activate and cut off the power, thereby providing full protection to the motor

Condenser coil

Petra's condenser coil is designed to deliver its duty with optimum performance for all design conditions. Coils are manufactured from seamless copper tubes mechanically expanded into aluminum fins. All coils are pressure tested by dry air up to 6,200 kPa (900 Psi) under water. They also undergo dry cleaning after manufacturing for optimum system cleanness

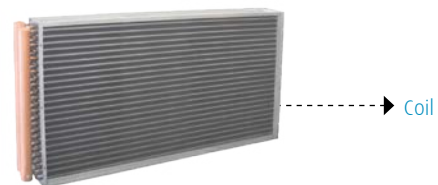

Low ambient control

- To permit the unit to operate in low ambient temperatures, head pressure control is maintained by varying the speed of the condenser fan motor using a speed regulator

Optional Features



Coil corrosion protection

- Copper fins
- Polyurethane Pre-coating (for aluminum fins)
- Polyurethane Post-coating (for aluminum & copper fins)

Water cooled condenser

The brazed plate heat exchanger condenser is a complete heat exchanger which consists of stainless steel plates, permanently brazed together with pure copper filter material. The plates are stacked together and form flow chambers for two fluids. Condenser shall work with a maximum allowable working pressure of 3,000 kPa (435 Psi). The condenser is insulated with 19 mm (3/4 inch) closed cell foam insulation



Brazed Plate Heat Exchanger

High and low pressure gauges

Optional pressure gauges for monitoring of refrigeration discharge and suction pressure. Additionally, the gauges are used to verify suitable refrigerant charge and proper system performance. The gauges shall be Bourdon type, stainless steel housing oil filled. Oil filling provides greater protection of the gauge internals from corrosive atmospheres. The gauges are provided with a dual scale of both PSI and BAR



Pressure gauges

Main disconnect switch

This is used to de energize the power supply to the chiller during servicing or repairing works due to the door interlock. It has an external handle that is installed on the electric panel door. The main disconnect switch has to be de-energized to open electric panel

The disconnect switch can be supplied with built in fuse or a non fuse type



Disconnect switch

Smoke detector

To provide protection for the system from the hazards of fire that may occur for any reason. The device has the ability to sense the existence of smoke, and if present, it will give a signal to the controller which will shut down the unit



Smoke detector

Infrared humidifiers

- The infrared humidifier consists of light intensity quartz infrared lamps over a stainless steel humidifier pan with water connection

Electrical component options

- External over load for each compressor
- External over load for each condenser fan motor

Computer Room Air Handling Unit - Optional



Chilled Water Coil (CRAH Unit)

- Petra chilled water precision cooling system is specifically designed to handle the high heat loads generated by computers and other electronic equipment, using an existing building chiller as a source of chilled water cooling
- Petra Computer Rooms with chilled water coils are designed to maintain environment parameters by precise, reliable control of room temperature, humidity and airflow for applications including Data centers, telecommunication offices, laboratories and pharmaceutical industry
- All coils are manufactured in-house in Petra coil manufacturing facility
- Coils are AHRI 410 certified & stamped
- Coils are designed to deliver their respective duties at optimum performance under all design conditions
- Coils are tested at 6,200 kPa (900 Psi) air pressure under water
- They also undergo dry chemical cleaning after coil manufacturing for optimum system cleanliness
- Airtight gaskets are used where coil pipes exit the unit casing. The sealing around the coil prevents air by-pass



CHW Coil



CHW Precision cooling system with EC Plug fans in down flow configuration - Up to 28,000 L/s (60,000 CFM)

Chilled Water Control Valve

- The chilled water valve provides modulating control action in response to room temperature and humidity as sensed by the microprocessor control. In addition, the feedback signal is received from the valve to indicate the actual opening percentage
- The valve can be a 3-way or 2-way to meet the requirements of the installed system



Chilled water precision unit with valve kit

Economical Chilled Water Systems

- Chilled water system offers suitable cooling and humidity control where a central water chiller is available as cooling source
- In these applications, a single chiller can be used for multiple air-conditioning units, providing savings on additional heat rejection components

Microprocessor Controller



Petra's microprocessor controller is engineered to meet the most demanding requirements for all control and data monitoring applications. It could be activated to perform different functions for cooling and heating applications. However, in order to render the microprocessor controller and peripherals easy to use by all skill levels of service teams, only the necessary functions for the safety sequence of operation and the alarm function are activated as standard conventional control such as, high pressure, flow switches, etc.

This allows service technicians to inspect and maintain such devices in the conventional manner



Petra air conditioning controller provides the following:

- Ease of use with LCD display and an attractive user-friendly interface.
- Remote start-up system command,
- General alarm dry-contact that can be interfaced with remote alarm device.
- Extended wall mounted display for remote control from up to 150 meters. (Optional) Safety and control time delays:
 - Time delay for the unit in start-up and shut down
 - Time delay between two subsequent starts of the same compressor
 - Time delay between activation of 1st and 2nd compressor (multi compressors unit option only)
 - Time delay between stops of 1st and 2nd compressor (multi compressors unit option only)
 - Time delay between activation of main fan and the compressor
- Control of activation of electrical heaters. (Reheat Function)
- Low ambient control.
- Compressor selection (activation) depending on operating hours (lead-lag management) to maintain the same operating hours for each compressor.
- Controlling the unit in de-humidification and humidification modes.
- Managing the stand-by and sequencing functions to equal operating hours. (Optional in case of multi units)
- Permanent parameters saving in the EPROM, to prevent data loss in case of power failure.
- Connectivity to Modbus, Lontalk or BACnet, B.M.S. (Optional)
- Supervisory and maintenance function with hardware and software provided by Petra. (Optional)
- Auto restart after power failure

Sequence of Control



Start Up

For initial startup, the following must be met:

- Control circuit breaker must be switched on
- Energize the microprocessor control through keypad, remote start/stop, schedule or BMS command
- All safeties condition satisfied

When the room temperature is above the target set point, the first compressor will start after the call for cooling. For chiller water type, the modulating valve (2-way or 3-way) will start increasing its opening from minimum opening up to 100% opening when cooling demand is maximum

The control strategy is designed to modulate the unit capacity to maintain the control sensor reading within the specified control band. To accomplish this, the Microprocessor controller will constantly monitor the control value, its rate of change and position in relationship to the control band and make adjustments accordingly

Main Temperature Control

- This is precise temperature control strategy to maintain the temperature within preset limit
- Main temperature is controlled by PI regulator on RETURN or SUPPLY temperature
- Supply temperature regulation is available only if a modulating device is available as CW valve or digital scroll

Dehumidification Control

- when the read of air relative humidity sensor is above the setpoint the controller will start give signals to run the compressors to make deep cooling to reduce air humidity. And the give start signals to electric heaters to compensate the air temperature and reduce it to the setpoint

Humidification / Dehumidification Changeover

- Humidification/dehumidification changeover is a function that allows the automatic change from humidification to dehumidification and vice versa. This logic controls the return humidity

Reheating Demand

- Reheating demand works to anticipate the cooling down on return temperature caused by de-humidification. There are 2 scenario in according to temperature regulation probe
- RETURN regulation: It works on the same threshold of low supply limit. In normal cooling when the low limit is reached the cooling demand is reduced, in dehumidification no reduction is done because heater help the supply temperature to work in a "acceptable range". Also present a Dehumidification Return Limit, if return temperature is lower than this threshold de-humidification is disabled

Displayed Data

The following standard data can be obtained on the screen

- Current room temperature
- Current supply temperature
- Current room humidity
- Temperature setpoint
- Humidity setpoint
- Cooling status
- Heating status
- Humidification status
- De-humidification status
- Compressor (ON/OFF)
- Chilled water valve opening
- Evaporator fan (ON/OFF)
- Electric heater (ON/OFF)
- Steam humidifier (ON/OFF)
- Date and time display
- Compressor operating hours
- Alarm history:
- Alarms with time and date stamp for each alarm

Safeties and Alarms

Gives the following alarm messages:

- Loss of airflow
- Dirty filters
- High discharge pressure
- Low suction pressure
- High and low room temperatures
- High and low room humidity
- Compressor thermal overload
- Condenser fan motor thermal overload
- Evaporator fan motor thermal overload
- Heaters' thermal overload
- Phase failure (under voltage, over voltage, phase imbalance, phase loss and phase reversal)
- Fire alarm (Fire system supplied by others)
- Water under floor
- Humidifier alarm
- Smoke detector alarm (Optional)

BMS Hard Wired

Within the hard wire structure there are six features as follows:

- Unit start / stop command
- Supply fan run status (optional)
- Supply fan trip status (optional)
- Compressor run status (optional)
- Compressor trip status (optional)
- Condenser fan run status (optional)
- Condenser fan trip status (optional)
- General alarm

USB in Microprocessor Controller:

- USB host: to connect a standard USB dongle for:
 - SW application upgrade
 - Download Pco logs
- USB device: to connect a PC (without external converter) for:
 - SW application upgrade
 - Download Pco logs
 - Configure and monitor the unit by commissioning tool



Petra Graphical Touch Screen [Optional]



Touch screen is an extremely high-tech user interface, with high resolution, and a microprocessor that allows the management of complex graphic images. It also displays animated icons, non-proportional fonts in Unicode format, humidity, pressure values and air speed. The touch screen function makes it easy for the user to manage more complex installation diagrams. A keypad on the side of the display can be used in all applications where the touch screen is not the preferred choice



Smart Watch Solution (Optional)

Introduction

Petra introduces the next generation of its control solutions: Smart Watch. Smart Watch is designed to make the interaction between user and HVAC units simpler and easier. Smart Watch centralizes the monitoring, operations and management of the HVAC system to achieve more efficient operations. Smart Watch has become an essential part of a modern HVAC system that contributes significantly to the savings potential and function of the building



Benefits of Using Smart Watch



- **Time Saving**

Through smart watch, you can monitor, control and operate a large HVAC system from one central location. Viewing all system alarms from one location with the ability to reset them. This reduces troubleshooting time and man-hours



- **Monitoring**

Creating a data logger for any variable in the system (return temperature, supply temperature, return humidity, flow rate, pressure...etc.)

Monitor the status of the unit devices (compressor, heater, humidifier, valve, and damper). This enables engineers and technicians to achieve a better understanding of their building and/or plant

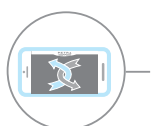

- **Flexibility**

The smart watch will give you the flexibility to change the set points for any unit, enable/disable any unit, heating/cooling selection for any unit and duty/standby functionality with time scheduling



- **Cost Reduction**

Using the network and serial communication dramatically reduce cabling and installation between units



- **Reporting**

Excel sheets can be created that show the system's behavior such as alarms log, temperatures, humidity...etc. and send them by email daily, weekly...etc.



- **Graphical Analysis**

You can get trends showing the temperature, humidity...etc. variations over a pre-set time period

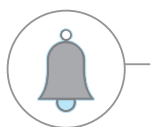

- **Alarms Management & Notifications**

Unit's alarms can be fully monitored and reported in a user-friendly manner. All alarms can be sent via e-mail or mobile. Alarms can be automatically classified as high priority and low priority



- **PC and Mobile WEB Interface**

Using your Smart Phone or Tablet, you can control the system remotely

Smart Watch Solution (Optional)



Smart Watch Features

- Compatible with BMS system
- Compatible with SCADA system
- Touch screen up to 13.3"
- Providing full details about your system
- Ability to control multi HVAC units in your system (chillers, package units, air handling units, close control units, ducted split units, fan coil units, exhaust fans...etc.)
- Using the Smart Watch, you can now exploit a new platform of services using the latest technologies available in the market and widely used in other applications
- Cloud computing, wireless connectivity & internet of things (IOT) in the HVAC units becomes a reality with this smart control system
- Security of the communications and data is the most top priority
- All systems will be secure with very well-known strong security methods
- Improve customer service levels through faster troubleshooting

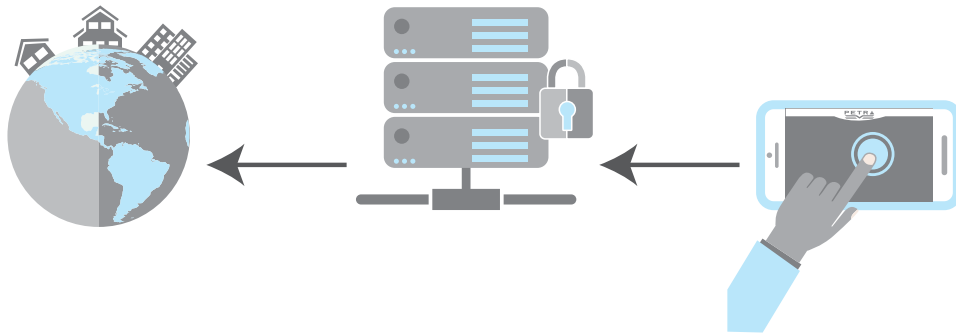

Smart Watch Insight

User friendly management station for the control, monitoring and analyzing for all integrating HVAC systems

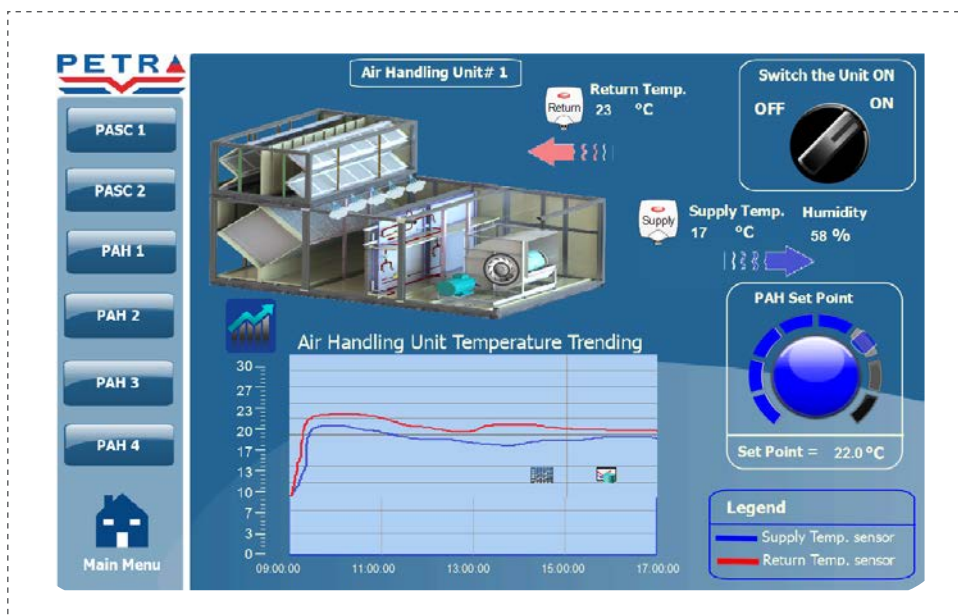

Web User Interfaces

Through this system, you can control your units through BMS, your smart phone or any hand help device

Also, through this system you will be able to send information through email alerts

You will be able to send the type of problem through an email alert

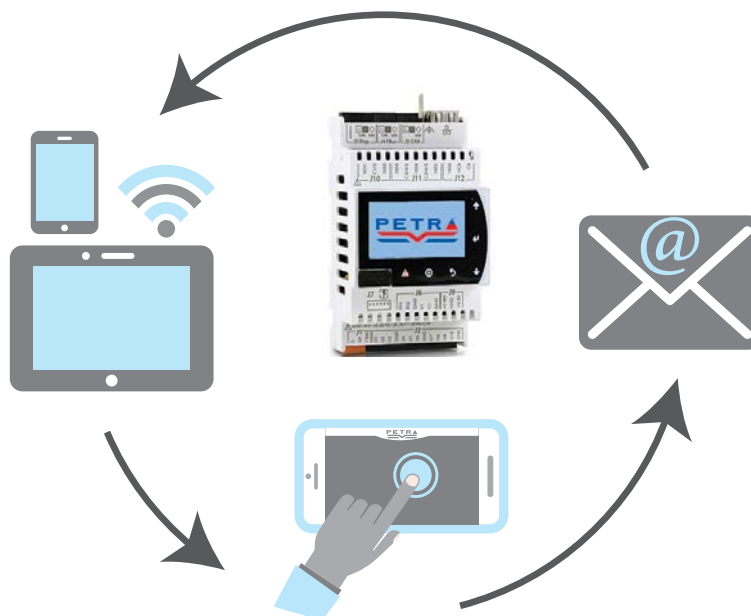

Technical Specifications

Power Supply	220-240Vac/1Ph/60Hz
Touch Keypad Type	TFT
Touch Keypad Resolution	800 x 1280, WVGA
Operating Temperature	0°C to 50°C
Storage Temperature	-20 °C to 70 °C
Operating and Storage Humidity	5 to 85% relative humidity
Interfaces	Modbus Port / USB Port

Physical Data - Indoor Unit - SI



	PASC4	45-1	55-1	85-2	115-2
COMPRESSOR					
Type		Hermetic Scroll			
Qty		1	1	2	2
Oil charge (Ckt1/Ckt2)	Liter	1.6	1.6	1.6/1.6	1.6/1.6
REFRIGERANT					
Refrigerant type		R-410A			
No. of independent circuits		1	1	2	2
Refrigerant charge @50Hz (Ckt1/Ckt2)	kg	3	4	3/3	4/4
Refrigerant charge @60Hz (Ckt1/Ckt2)	kg	4	5	4/4	5/5
COIL					
Qty		1			
Fins per meter		551			
No. of rows		4			
Total face area	m ²	0.4	0.5	0.8	1.0
Max working refrigeration pressure	Pa	4,100			
FAN					
Type		Direct Drive EC Fan			
Qty		1			
Nominal speed	rpm	2,180	2,180	2,180	2,040
No. of blades		7			
Nominal diameter	mm	275	275	450	450
Nominal air flow rate	L/s	944	1,180	1,770	2,359
Motor power	kW	1.3	1.3	3.6	3.6
AIR FILTER					
Type		Pleated filter			
Efficiency		MERV 8 - G4			
Thickness	mm	50			
STEAM HUMIDIFIER					
Type		Self Generated Electrode Type			
Capacity	kg/hr	3	3	5	8
ELECTRIC HEATER					
Type		Finned Tube Elements			
Capacity	kW	3	3	6	7.5
GENERAL					
Unit weight	kg	260	280	420	500

Note

- Refrigerant charge is based on 5m distance between indoor and outdoor units
- Weights are based on standard design components, selected options may add weight on the unit
- Indoor unit is shipped with a nitrogen charge

	PASC4	145-2	175-2	200-2	250-2
COMPRESSOR					
Type		Hermetic Scroll			
Qty		2			
Oil charge (Ckt1/Ckt2)	Liter	1.7/1.7	2.5/2.5	3.3/3.3	3.3/3.3
REFRIGERANT					
Refrigerant type		R-410A			
No. of independent circuits		2			
Refrigerant charge @50Hz (Ckt1/Ckt2)	kg	5/5	6/6	8/8	8/8
Refrigerant charge @60Hz (Ckt1/Ckt2)	kg	6/6	7/7	9/9	9/9
COIL					
Qty		1			
Fins per meter		551			
No. of rows		4	4	6	6
Total face area	m ²	1.3	1.6	1.6	1.6
Max working refrigeration pressure	Pa	4,100			
FAN					
Type		Direct Drive EC Fan			
Qty		2			
Nominal speed	rpm	2,180	2,040	2,040	2,040
No. of blades					
Nominal diameter	mm	500	500	450	450
Nominal air flow rate	L/s	2,926	3,634	4,011	4,483
Motor power	kW	3.9	7.4	2x3.6	2x3.6
AIR FILTER					
Type		Pleated filter			
Efficiency		MERV 8 - G4			
Thickness	mm	50			
STEAM HUMIDIFIER					
Type		Self Generated Electrode Type			
Capacity	kg/hr	10	10	15	15
ELECTRIC HEATER					
Type		Finned Tube Elements			
Capacity	kW	9	9	12	12
GENERAL					
Unit weight	kg	600	750	780	800

Note

- Refrigerant charge is based on 5m distance between indoor and outdoor units
- Weights are based on standard design components, selected options may add weight on the unit
- Indoor unit is shipped with a nitrogen charge

Physical Data - Indoor Unit - IMP



	PASC4	45-1	55-1	85-2	115-2
COMPRESSOR					
Type		Hermetic Scroll			
Qty		1	1	2	2
Oil charge (Ckt1/Ckt2)	gal	0.4	0.4	0.4/0.4	0.4/0.4
REFRIGERANT					
Refrigerant type		R-410A			
No. of independent circuits		1	1	2	2
Refrigerant charge @50Hz (Ckt1/Ckt2)	lb	7	9	7/7	9/9
Refrigerant charge @60Hz (Ckt1/Ckt2)	lb	8	10	8/8	10/10
COIL					
Qty		1			
Fins per Inch		14			
No. of rows		4			
Total face area	ft ²	4.5	5.5	8.4	11.1
Max working refrigeration pressure	psig	600			
FAN					
Type		Direct Drive EC Fan			
Qty		1			
Nominal speed	rpm	2,180	2,180	2,180	2,040
No. of blades		7			
Nominal diameter	inch	11	11	18	18
Nominal air flow rate	cfm	2,000	2,500	3,750	5,000
Motor power	kW	1.3	1.3	3.6	3.6
AIR FILTER					
Type		Pleated filter			
Efficiency		MERV 8 - G4			
Thickness	inch	2			
STEAM HUMIDIFIER					
Type		Self Generated Electrode Type			
Capacity	kg/hr	3	3	5	8
ELECTRIC HEATER					
Type		Finned Tube Elements			
Capacity	kW	3	3	6	7.5
GENERAL					
Unit weight	lb	573	617	926	1,103

Note

- Refrigerant charge is based on 5m distance between indoor and outdoor units
- Weights are based on standard design components, selected options may add weight on the unit
- Indoor unit is shipped with a nitrogen charge

	PASC4	145-2	175-2	200-2	250-2
COMPRESSOR					
Type		Hermetic Scroll			
Qty		2			
Oil charge (Ckt1/Ckt2)	gal	0.4/0.4	0.7/0.7	0.8/0.8	0.8/0.8
REFRIGERANT					
Refrigerant type		R-410A			
No. of independent circuits		2			
Refrigerant charge @50Hz (Ckt1/Ckt2)	lb	11/11	14/14	17/17	18/18
Refrigerant charge @60Hz (Ckt1/Ckt2)	lb	13/13	16/16	19/19	21/21
COIL					
Qty		1			
Fins per Inch		14			
No. of rows		4	4	6	6
Total face area	ft ²	13.7	16.9	16.9	16.9
Max working refrigeration pressure	psig	600			
FAN					
Type		Direct Drive EC Fan			
Qty		2			
Nominal speed	rpm	2,180	2,040	2,040	2,040
No. of blades		7			
Nominal diameter	inch	20	20	18	18
Nominal air flow rate	cfm	6,200	7,700	9,000	10,000
Motor power	kW	3.9	7.4	2x3.6	2x3.6
AIR FILTER					
Type		Pleated filter			
Efficiency		MERV 8 - G4			
Thickness	inch	2			
STEAM HUMIDIFIER					
Type		Self Generated Electrode Type			
Capacity	kg/hr	10	10	15	15
ELECTRIC HEATER					
Type		Finned Tube Elements			
Capacity	kW	9	9	12	12
GENERAL					
Unit weight	lb	1,323	1,659	1,720	1,764

Note

- Refrigerant charge is based on 5m distance between indoor and outdoor units
- Weights are based on standard design components, selected options may add weight on the unit
- Indoor unit is shipped with a nitrogen charge

Physical Data - Outdoor Unit - SI



	PASC4	45-1	55-1	85-2	115-2
COIL					
Qty			1		
Fins per meter			472		
No. of rows		2	2	4	3
Total face area	m ²	0.8	1.0	1.1	1.4
Max working refrigeration pressure	Pa	4,100			
FAN					
Type		Direct Drive External Rotor Axial Fan			
Qty		1	1	2	2
Nominal speed (50/60Hz)	rpm	900/1100			
No. of blades		5			
Nominal diameter	mm	630			
Total air flow rate (50 Hz)	L/s	2,735	2,887	4,999	4,999
Total air flow rate (60 Hz)	L/s	3,100	3,260	5,727	5,727
Motor power (50/60Hz)	HP	0.6/0.8			
GENERAL					
Unit weight	kg	95	110	135	165

	PASC4	145-2	175-2	200-2	250-2
COIL					
Qty			1		
Fins per meter			472		
No. of rows			4		
Total face area	m ²	1.7	2.1	2.7	2.7
Max working refrigeration pressure	Pa	4,100			
FAN					
Type		Direct Drive External Rotor Axial Fan			
Qty		2	3	3	3
Nominal speed (50/60Hz)	rpm	900/1100			
No. of blades		5			
Nominal diameter	mm	630			
Total air flow rate (50 Hz)	L/s	5,321	8,202	8,202	8,202
Total air flow rate (60 Hz)	L/s	6,058	9,299	9,299	9,299
Motor power (50/60Hz)	HP	0.6/0.8			
GENERAL					
Unit weight	kg	200	260	260	364

Note

- Weights are based on standard design components, selected options may add weight on the unit
- Outdoor unit is shipped with a nitrogen charge

Physical Data - Outdoor Unit - IMP



	PASC4	45-1	55-1	85-2	115-2
COIL					
Qty				1	
Fins per Inch				12	
No. of rows		2	2	4	3
Total face area	ft ²	8.3	10.6	11.7	14.7
Max working refrigeration pressure	psig	600			
FAN					
Type		Direct Drive External Rotor Axial Fan			
Qty		1	1	2	2
Nominal speed (50/60Hz)	rpm	900/1100			
No. of blades		5			
Nominal diameter	inch	25			
Total air flow rate (50 Hz)	cfm	5,796	6,117	10,594	10,594
Total air flow rate (60 Hz)	cfm	6,570	6,909	12,137	12,137
Motor power (50/60Hz)	HP	0.6/0.8			
GENERAL					
Unit weight	lb	209	243	298	364

	PASC4	145-2	175-2	200-2	250-2
COIL					
Qty				1	
Fins per Inch				12	
No. of rows				4	
Total face area	ft ²	17.8	22.7	29.3	29.3
Max working refrigeration pressure	psig	600			
FAN					
Type		Direct Drive External Rotor Axial Fan			
Qty		2	3	3	3
Nominal speed (50/60Hz)	rpm	900/1100			
No. of blades		5			
Nominal diameter	inch	25			
Total air flow rate (50 Hz)	cfm	11,276	17,381	17,381	17,381
Total air flow rate (60 Hz)	cfm	12,838	19,705	19,705	19,705
Motor power (50/60Hz)	HP	0.6/0.8			
GENERAL					
Unit weight	lb	441	573	573	803

Note

- Weights are based on standard design components, selected options may add weight on the unit
- Outdoor unit is shipped with a nitrogen charge

Model Layout



Up Flow Design

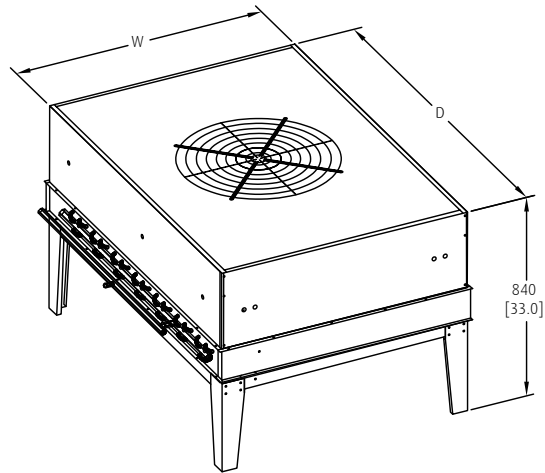
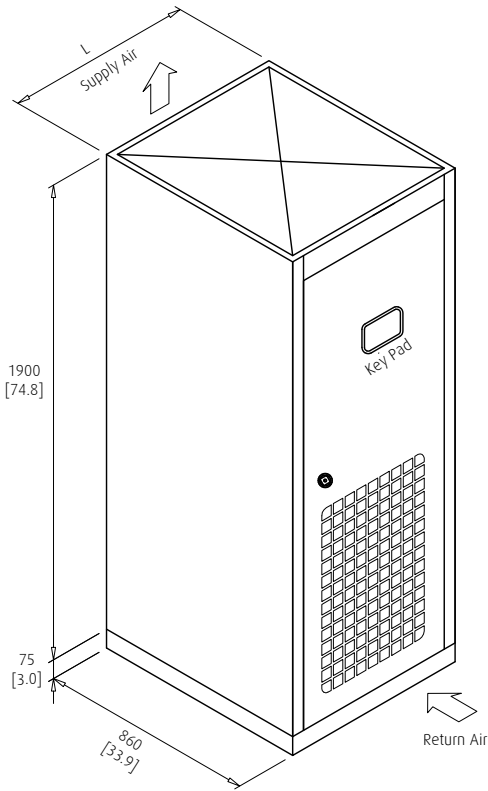

SI	Indoor Unit		Outdoor Unit
	L	W	D
PASC 45-1	750	915	840
PASC 55-1	750	965	1020
PASC 85-2	1100	1625*	840

IMP	Indoor Unit		Outdoor Unit
	L	W	D
PASC 45-1	29.5	36.0	33.1
PASC 55-1	29.5	38.0	40.2
PASC 85-2	43.3	64.0*	33.1

All dimensions are in mm

All dimensions are in inch

Note

- * PASC4 85-2 has two condenser fans
- For unit clearance, please refer to page 30

Up Flow Design

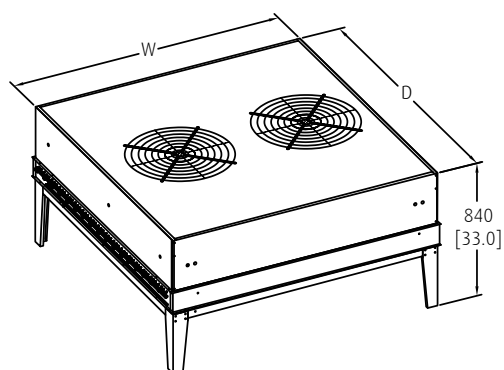
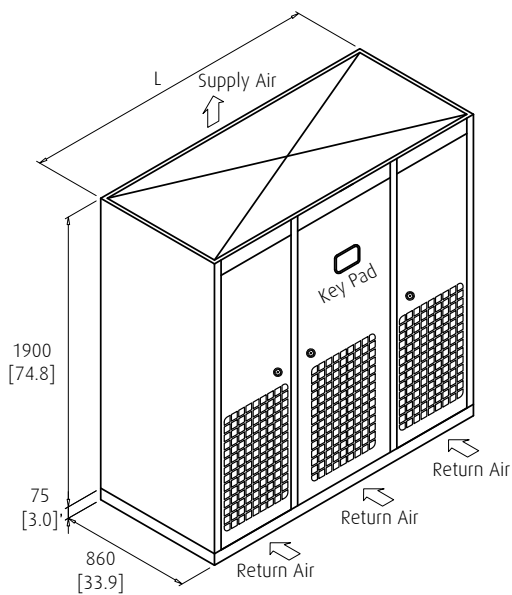

SI	Indoor Unit		Outdoor Unit	
	L	W	W	D
PASC 115-2	1350	1625	840	
PASC 145-2	1600	1625	1020	

IMP	Indoor Unit		Outdoor Unit	
	L	W	W	D
PASC 115-2	53.1	64.0	33.1	
PASC 145-2	63.0	64.0	40.2	

All dimensions are in mm

All dimensions are in inch

Note

- For unit clearance, please refer to page 30

Model Layout



Up Flow Design

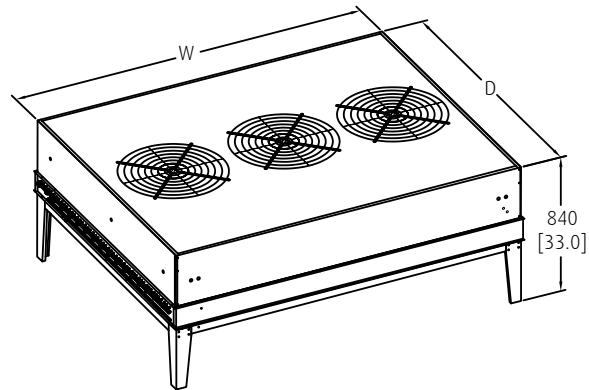
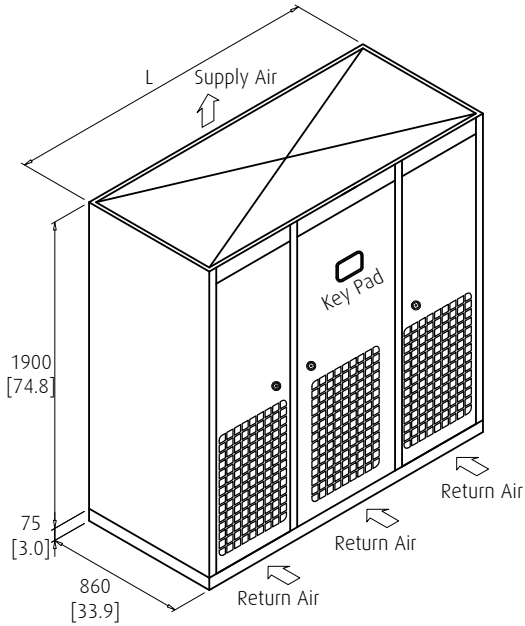

SI	Indoor Unit		Outdoor Unit
	L	W	D
PASC 175-2	1960	1730	1220
PASC 200-2	1960	2235	1220
PASC 250-2	1960	2235	1220

IMP	Indoor Unit		Outdoor Unit
	L	W	D
PASC 175-2	77.2	68.1	48.0
PASC 200-2	77.2	88.0	48.0
PASC 250-2	77.2	88.0	48.0

All dimensions are in mm

All dimensions are in inch

Note

- For unit clearance, please refer to page 30

Down Flow Design

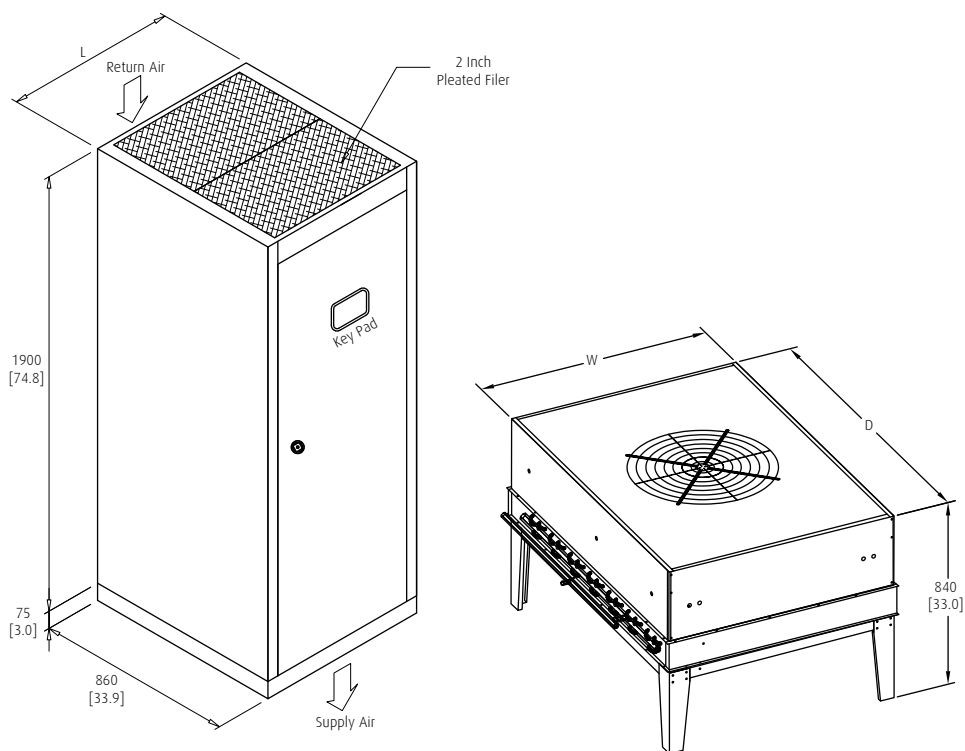

SI	Indoor Unit		Outdoor Unit	
	L	W	W	D
PASC 45-1	750	915	915	840
PASC 55-1	750	965	965	1020
PASC 85-2	1100	1625*	1625*	1020

IMP	Indoor Unit		Outdoor Unit	
	L	W	W	D
PASC 45-1	29.5	36.0	36.0	33.1
PASC 55-1	29.5	38.0	38.0	40.2
PASC 85-2	43.3	64.0*	64.0*	40.2

All dimensions are in mm

All dimensions are in inch

Note

- * PASC4 85-2 has two condenser fans
- For unit clearance, please refer to page 30

Model Layout



Down Flow Design

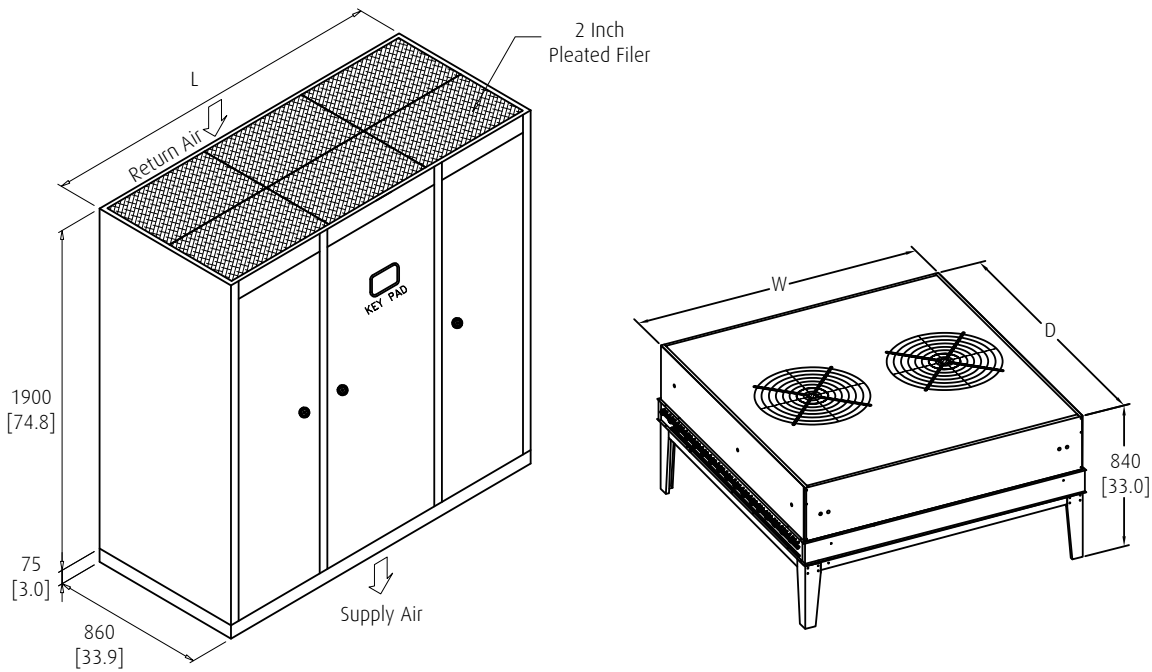

SI	Indoor Unit	Outdoor Unit	
	L	W	D
PASC 115-2	1350	1625	840
PASC 145-2	1600	1625	1020

IMP	Indoor Unit	Outdoor Unit	
	L	W	D
PASC 115-2	53.1	64.0	33.1
PASC 145-2	63.0	64.0	40.2

All dimensions are in mm

All dimensions are in inch

Note

- For unit clearance, please refer to page 30

Down Flow Design

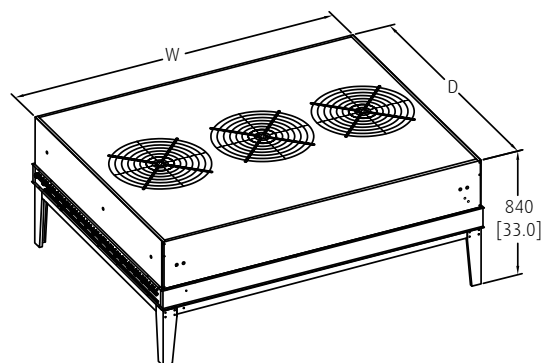
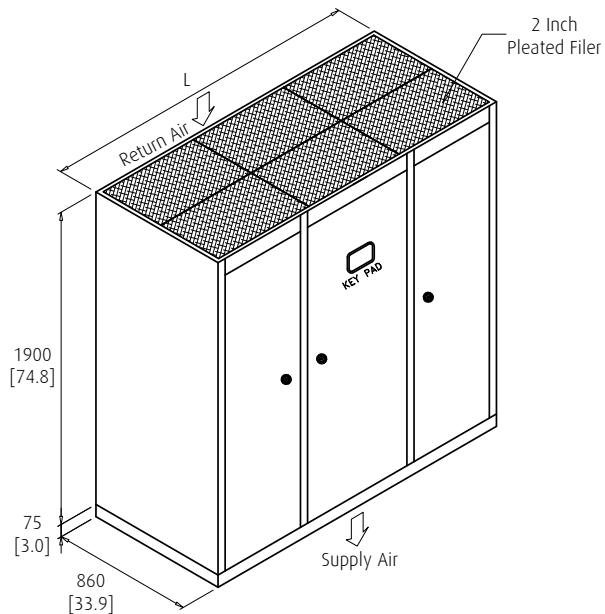

SI	Indoor Unit	Outdoor Unit	
	L	W	D
PASC 175-2	1960	2235	1220
PASC 200-2	1960	2235	1220
PASC 250-2	1960	2235	1220

IMP	Indoor Unit	Outdoor Unit	
	L	W	D
PASC 175-2	77.2	88.0	48.0
PASC 200-2	77.2	88.0	48.0
PASC 250-2	77.2	88.0	48.0

All dimensions are in mm

All dimensions are in inch

Note

- For unit clearance, please refer to page 30

Unit Clearance



Up Flow Design

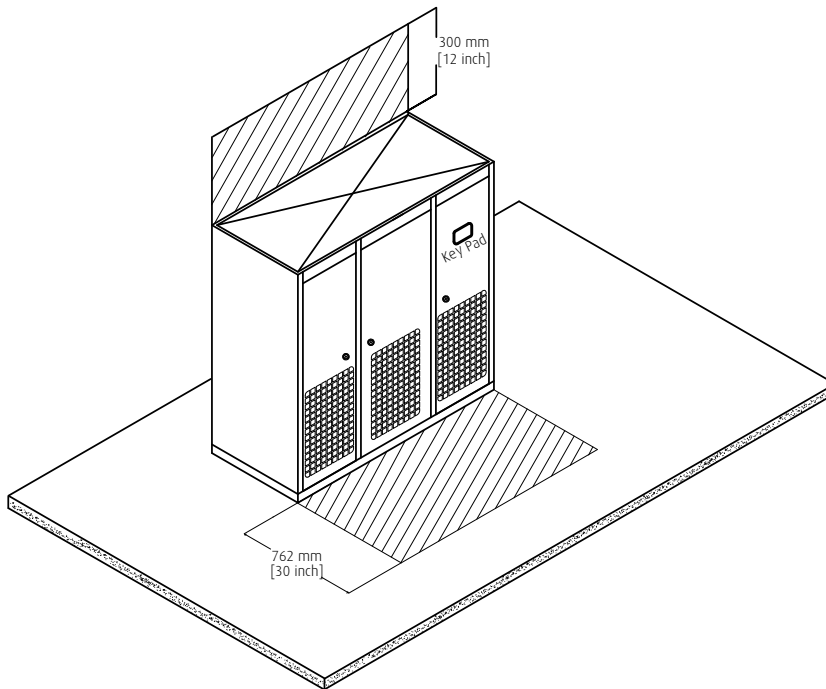

Down Flow Design

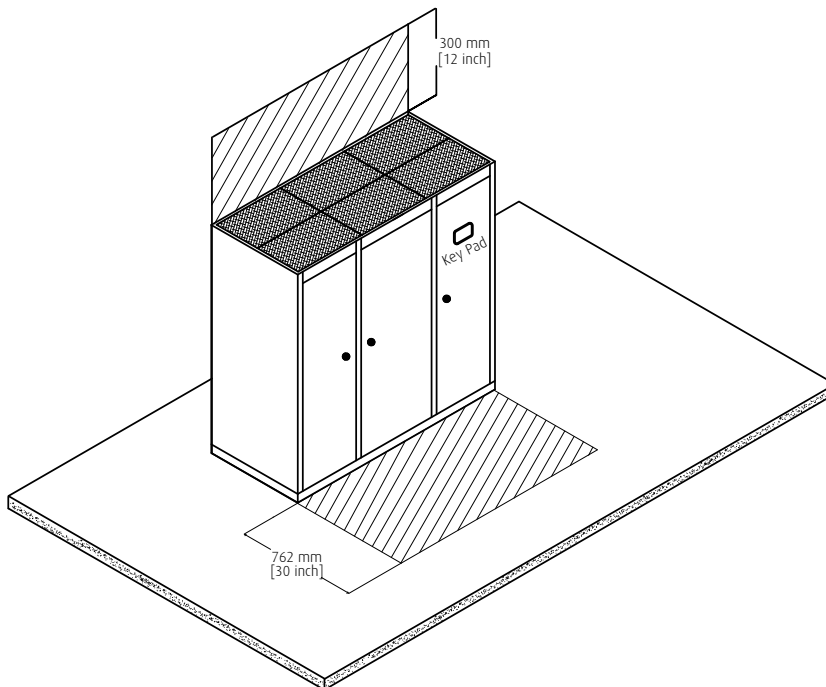

Note

- Unit must be leveled
- Service area above & in front is the minimum accepted for any other site installation requirements or multiple unit installation, please contact your nearest Petra sales office

Selection Procedure



Before you proceed with unit selection, the capacity should be corrected according to the location where the unit will be installed.

Altitude Correction Factors:

Since air density decreases at elevations above sea level, the fans provide less air mass over the condenser so unit performance should be corrected when operated substantially above sea level.

Selection:

To select any Computer Room from the PASC4 series, the following should be provided:

- Design capacity in kW (MBH) of refrigeration
- Entering dry & wet bulb temperature in °C (°F)
- Entering air flow rate in L/s (CFM)
- Altitude of space where the computer room is to be installed

Example:

Use the following data:	
Design capacity	85.0 kW (290.0 MBH)
Entering condenser air	35 °C (95 °F)
Entering air flow rate	24720 L/s (10,000 CFM)
Altitude	305 m (1000 ft)
Power supply	380V/3Ph/60Hz

Altitude Meter [ft]	Correction Factor	Compressor Power Factor
Sea Level	1.000	1.000
305 (1000)	0.995	1.005
610 (2000)	0.990	1.010
915 (3000)	0.985	1.015
1220 (4000)	0.980	1.020
1525 (5000)	0.973	1.025
1830 (6000)	0.976	1.030
2135 (7000)	0.960	1.035
2440 (8000)	0.950	1.040

Selection Procedure:

The capacity should be corrected at 305 m (1000 ft)
 Correction of capacity: $85.0 (290.0) \div 0.995$
 $= 84.4 \text{ kW (291.5 MBH)}$

Result of selection:

From the performance table on page 35, the operating data for the selected unit:

- Unit:	PASC4 200
- Total Cooling Capacity:	38.9 kW (132.8 MBH)
- Sensible Cooling Capacity:	31.1 kW (106.0 MBH)
- Power input:	$9.5 \times 1.005 = 9.6 \text{ kW}$

Performance Data - SI



• 50 Hz

(PASC4)	AFR (L/s)	AMBIENT TEMPERATURE (°C)														
		30			35			40			45			50		
		T.CAP (kW)	S.CAP (kW)	PI (kW)	T.CAP (kW)	S.CAP (kW)	PI (kW)	T.CAP (kW)	S.CAP (kW)	PI (kW)	T.CAP (kW)	S.CAP (kW)	PI (kW)	T.CAP (kW)	S.CAP (kW)	PI (kW)
45	849	15.4	15.4	2.7	14.8	14.8	3.0	14.2	14.2	3.4	13.5	13.5	3.8	12.8	12.8	4.3
	944	15.6	15.6	2.7	15.0	15.0	3.0	14.4	14.4	3.4	13.7	13.7	3.8	13.0	13.0	4.3
	1,062	15.9	15.9	2.7	15.3	15.3	3.0	14.6	14.6	3.4	13.9	13.9	3.8	13.1	13.1	4.3
55	1,180	19.6	19.6	3.4	18.8	18.8	3.9	18.0	18.0	4.4	17.1	17.1	5.0	16.1	16.1	5.7
	1,321	19.9	19.9	3.4	19.1	19.1	3.9	18.3	18.3	4.4	17.4	17.4	5.0	16.4	16.4	5.7
	2,004	20.8	20.8	3.4	20.0	20.0	3.9	19.1	19.1	4.4	18.2	18.2	5.0	17.3	17.3	5.7
85	1,770	30.9	30.9	5.2	29.7	29.7	5.9	28.5	28.5	6.6	27.2	27.2	7.4	25.8	25.8	8.4
	2,006	31.4	31.4	5.2	30.2	30.2	5.9	29.0	29.0	6.6	27.6	27.6	7.4	26.2	26.2	8.4
	3,006	32.9	32.9	5.2	31.7	31.7	5.9	30.3	30.3	6.6	28.8	28.8	7.5	27.1	27.1	8.5
115	2,359	39.0	39.0	6.9	37.4	37.4	7.9	35.8	35.8	8.9	34.0	34.0	10.2	32.1	32.1	11.6
	2,595	39.5	39.5	7.0	37.9	37.9	7.9	36.2	36.2	9.0	34.4	34.4	10.2	32.4	32.4	11.6
	4,009	41.4	41.4	7.0	39.7	39.7	8.0	37.8	37.8	9.1	35.8	35.8	10.3	33.0	33.0	11.7
145	2,926	43.4	43.4	7.6	41.7	41.7	8.5	39.8	39.8	9.5	37.8	37.8	10.6	35.7	35.7	11.8
	3,209	43.9	43.9	7.6	42.1	42.1	8.5	40.2	40.2	9.5	38.2	38.2	10.6	36.1	36.1	11.8
	4,971	45.7	45.7	7.8	44.0	44.0	8.5	42.3	42.3	9.6	40.5	40.5	10.7	38.7	38.7	11.9
175	3,634	58.0	58.0	10.1	55.8	55.8	11.1	53.5	53.5	12.3	50.9	50.9	13.6	48.1	48.1	15.2
	4,011	58.7	58.7	10.2	56.5	56.5	11.2	54.1	54.1	12.3	51.5	51.5	13.6	48.7	48.7	15.2
	6,173	61.4	61.4	10.3	59.0	59.0	11.3	56.3	56.3	12.5	53.7	53.7	13.6	51.9	51.9	15.3
200	4,247	76.5	76.5	13.6	73.5	73.5	15.2	70.2	70.2	16.9	66.6	66.6	18.9	62.5	62.5	21.2
	4,719	77.5	77.5	13.7	74.5	74.5	15.2	71.1	71.1	16.9	67.4	67.4	18.9	63.2	63.2	21.2
	7,216	81.1	81.1	13.9	77.8	77.8	15.4	74.8	74.8	16.9	71.3	71.3	18.9	67.6	67.6	21.2
250	4,719	83.0	83.0	15.7	79.5	79.5	17.5	75.8	75.8	19.5	72.0	72.0	21.7	67.7	67.7	24.2
	5,191	84.0	84.0	15.8	80.5	80.5	17.6	76.7	76.7	19.6	72.8	72.8	21.7	68.4	68.4	24.3
	8,018	88.0	88.0	16.0	84.1	84.1	17.8	80.0	80.0	19.8	76.2	76.2	21.7	72.1	72.1	24.3

Legend

AFR : Air Flow Rate
 T.CAP : Total Cooling Capacity
 S.CAP : Sensible Cooling Capacity
 PI : Power input

Note

- Performance data are calculated based on 29.4/18°C entering dry bulb/ entering wet bulb temperature
- Power input in this page should not be used for cable or breaker selection. MCA and MOP values in the electrical data section should be referred for the same

• 60 Hz

	AFR (L/s)	AMBIENT TEMPERATURE (°C)														
		30			35			40			45			50		
		T.CAP (kW)	S.CAP (kW)	PI (kW)	T.CAP (kW)	S.CAP (kW)	PI (kW)	T.CAP (kW)	S.CAP (kW)	PI (kW)	T.CAP (kW)	S.CAP (kW)	PI (kW)	T.CAP (kW)	S.CAP (kW)	PI (kW)
45	849	17.3	17.3	3.3	16.9	16.9	3.7	16.3	16.3	4.2	15.5	15.5	4.7	14.6	14.6	5.2
	944	17.8	17.8	3.3	17.2	17.2	3.7	16.5	16.5	4.2	15.7	15.7	4.7	14.9	14.9	5.2
	1,062	18.1	18.1	3.3	17.5	17.5	3.7	16.8	16.8	4.2	16.0	16.0	4.7	15.1	15.1	5.2
55	1,180	22.0	22.0	4.1	21.1	21.1	4.6	20.3	20.3	5.2	19.3	19.3	5.9	18.3	18.3	6.6
	1,321	22.3	22.3	4.2	21.5	21.5	4.7	20.5	20.5	5.2	19.6	19.6	5.9	18.5	18.5	6.6
	2,004	23.4	23.4	4.2	22.5	22.5	4.7	21.5	21.5	5.3	20.5	20.5	5.9	19.3	19.3	6.7
85	1,770	35.2	35.2	6.5	34.0	34.0	7.3	32.7	32.7	8.2	31.3	31.3	9.2	29.6	29.6	10.2
	2,006	35.9	35.9	6.5	34.6	34.6	7.3	33.4	33.4	8.2	31.8	31.8	9.2	30.1	30.1	10.2
	3,006	37.8	37.8	6.5	36.5	36.5	7.3	35.0	35.0	8.2	33.4	33.4	9.2	31.6	31.6	10.3
115	2,359	43.8	43.8	8.4	42.1	42.1	9.4	40.3	40.3	10.6	38.4	38.4	11.9	36.3	36.3	13.4
	2,595	44.4	44.4	8.4	42.6	42.6	9.4	40.8	40.8	10.6	38.8	38.8	11.9	36.7	36.7	13.5
	4,009	46.7	46.7	8.5	44.8	44.8	9.6	42.8	42.8	10.7	40.6	40.6	12.1	38.4	38.4	13.6
145	2,926	49.9	49.9	9.5	48.0	48.0	10.5	45.9	45.9	11.6	43.6	43.6	12.9	41.3	41.3	14.4
	3,209	50.5	50.5	9.5	48.6	48.6	10.5	46.4	46.4	11.7	44.2	44.2	12.9	41.7	41.7	14.4
	4,971	53.1	53.1	9.7	50.9	50.9	10.7	48.7	48.7	11.8	46.2	46.2	13.1	44.1	44.1	14.4
175	3,634	66.0	66.0	12.4	63.5	63.5	13.7	61.0	61.0	15.1	58.3	58.3	16.6	55.4	55.4	18.5
	4,011	66.9	66.9	12.4	64.4	64.4	13.7	61.8	61.8	15.1	59.1	59.1	16.7	56.1	56.1	18.5
	6,173	70.5	70.5	12.6	67.7	67.7	13.8	64.9	64.9	15.2	61.9	61.9	16.8	58.7	58.7	18.6
200	4,247	87.6	87.6	17.1	84.2	84.2	19.0	80.4	80.4	21.1	76.2	76.2	23.6	71.8	71.8	26.3
	4,719	88.9	88.9	17.2	85.5	85.5	19.0	81.6	81.6	21.2	77.3	77.3	23.7	72.7	72.7	26.4
	7,216	93.4	93.4	17.4	89.7	89.7	19.3	85.5	85.5	21.5	81.0	81.0	23.9	75.9	75.9	26.6
250	4,719	94.1	94.1	19.8	90.4	90.4	21.8	86.2	86.2	24.1	81.9	81.9	26.6	77.2	77.2	29.5
	5,191	95.3	95.3	19.9	91.5	91.5	21.8	87.3	87.3	24.2	82.9	82.9	26.7	78.1	78.1	29.6
	8,018	100.2	100.2	20.2	96.0	96.0	22.2	91.4	91.4	24.5	86.8	86.8	27.0	81.5	81.5	29.9

Legend

AFR : Air Flow Rate
T.CAP : Total Cooling Capacity
S.CAP : Sensible Cooling Capacity
PI : Power input

Note

- Performance data are calculated based on 29.4/18°C entering dry bulb/ entering wet bulb temperature
- Power input in this page should not be used for cable or breaker selection. MCA and MOP values in the electrical data section should be referred for the same

Performance Data - IMP



• 50 Hz

(PASC4)	AFR (CFM)	Ambient Temperature (°F)														
		85			95			105			115			125		
		T.CAP (MBH)	S.CAP (MBH)	PI (kW)	T.CAP (MBH)	S.CAP (MBH)	PI (kW)	T.CAP (MBH)	S.CAP (MBH)	PI (kW)	T.CAP (MBH)	S.CAP (MBH)	PI (kW)	T.CAP (MBH)	S.CAP (MBH)	PI (kW)
45	1,800	52.7	52.7	2.6	50.5	50.5	3.0	48.1	48.1	3.4	45.6	45.6	3.9	42.8	42.8	4.4
	2,000	53.5	53.5	2.6	51.3	51.3	3.0	48.8	48.8	3.4	46.2	46.2	3.9	43.4	43.4	4.4
	2,250	54.4	54.4	2.6	52.1	52.1	3.0	49.5	49.5	3.4	46.9	46.9	3.9	43.9	43.9	4.5
55	2,500	67.2	67.2	3.4	64.2	64.2	3.9	61.0	61.0	4.5	57.7	57.7	5.1	54.0	54.0	5.9
	2,800	68.2	68.2	3.4	65.2	65.2	3.9	61.9	61.9	4.5	58.5	58.5	5.1	54.7	54.7	5.9
	4,247	71.4	71.4	3.4	68.1	68.1	3.9	64.6	64.6	4.5	60.8	60.8	5.1	58.1	58.1	5.9
85	3,750	105.9	105.9	5.2	101.5	101.5	5.9	96.9	96.9	6.7	91.7	91.7	7.6	86.3	86.3	8.7
	4,250	107.8	107.8	5.2	103.2	103.2	5.9	98.4	98.4	6.7	93.2	93.2	7.7	87.6	87.6	8.7
	6,371	112.9	112.9	5.2	108.0	108.0	5.9	102.7	102.7	6.7	97.1	97.1	7.7	91.2	91.2	8.7
115	5,000	133.6	133.6	6.8	127.7	127.7	7.9	121.4	121.4	9.1	114.4	114.4	10.5	107.1	107.1	12.0
	5,500	135.3	135.3	6.8	129.3	129.3	7.9	122.8	122.8	9.1	115.8	115.8	10.5	108.3	108.3	12.1
	8,495	141.9	141.9	6.9	135.4	135.4	8.0	128.5	128.5	9.2	120.2	120.2	10.3	110.5	110.5	12.1
145	6,200	148.6	148.6	7.6	142.2	142.2	8.5	135.1	135.1	9.6	127.5	127.5	10.8	120.1	120.1	11.8
	6,800	150.3	150.3	7.6	143.7	143.7	8.5	136.4	136.4	9.6	128.7	128.7	10.9	121.2	121.2	11.8
	10,533	156.8	156.8	7.6	148.9	148.9	8.5	142.1	142.1	9.6	136.2	136.2	10.9	130.3	130.3	11.9
175	7,700	198.6	198.6	10.0	190.3	190.3	11.1	181.5	181.5	12.4	171.7	171.7	13.9	160.7	160.7	15.8
	8,500	201.2	201.2	10.0	192.7	192.7	11.2	183.7	183.7	12.4	173.6	173.6	14.0	162.5	162.5	15.8
	13,082	210.4	210.4	10.2	201.2	201.2	11.3	191.4	191.4	12.6	180.3	180.3	14.0	175.2	175.2	15.8
200	9,000	262.2	262.2	13.5	250.7	250.7	15.2	238.0	238.0	17.1	223.9	223.9	19.4	208.5	208.5	22.0
	10,000	265.8	265.8	13.5	254.1	254.1	15.2	241.2	241.2	17.2	226.6	226.6	19.4	210.9	210.9	22.0
	15,291	277.8	277.8	13.7	265.6	265.6	15.4	253.1	253.1	17.2	241.2	241.2	19.4	228.7	228.7	22.0
250	10,000	284.5	284.5	15.6	271.4	271.4	17.5	257.4	257.4	19.7	242.4	242.4	22.2	226.0	226.0	25.1
	11,000	287.8	287.8	15.6	274.6	274.6	17.6	260.4	260.4	19.8	245.0	245.0	22.3	228.3	228.3	25.2
	16,990	301.1	301.1	15.9	286.9	286.9	17.8	271.6	271.6	20.0	258.4	258.4	22.3	244.2	244.2	25.2

Legend

AFR : Air Flow Rate
 T.CAP : Total Cooling Capacity
 S.CAP : Sensible Cooling Capacity
 PI : Power input

Note

- Performance data are calculated based on 85/64.4°F entering dry bulb/entering wet bulb temperature
- Power input in this page should not be used for cable or breaker selection. MCA and MOP values in the electrical data section should be referred for the same

• 60 Hz

(PASC4)	AFR (CFM)	Ambient Temperature (°F)														
		85			95			105			115			125		
		T.CAP (MBH)	S.CAP (MBH)	PI (kW)	T.CAP (MBH)	S.CAP (MBH)	PI (kW)	T.CAP (MBH)	S.CAP (MBH)	PI (kW)	T.CAP (MBH)	S.CAP (MBH)	PI (kW)	T.CAP (MBH)	S.CAP (MBH)	PI (kW)
45	1,800	59.9	59.0	3.3	57.7	57.7	3.7	55.2	55.2	4.2	52.3	52.3	4.8	48.8	48.8	5.4
	2,000	60.9	60.9	3.3	58.7	58.7	3.7	56.1	56.1	4.2	53.1	53.1	4.8	49.5	49.5	5.4
	2,250	62.0	62.0	3.3	59.7	59.7	3.7	57.0	57.0	4.2	54.0	54.0	4.8	50.3	50.3	5.4
55	2,500	75.3	75.3	4.1	72.1	72.1	4.6	68.8	68.8	5.3	65.0	65.0	6.0	61.0	61.0	6.9
	2,800	76.6	76.6	4.1	73.3	73.3	4.7	69.8	69.8	5.3	66.0	66.0	6.0	61.9	61.9	6.9
	4,247	80.4	80.4	4.1	76.9	76.9	4.7	73.0	73.0	5.4	69.0	69.0	6.1	64.5	64.5	7.0
85	3,750	120.5	120.5	6.4	116.0	116.0	7.3	111.1	111.1	8.3	105.5	105.5	9.4	98.7	98.7	10.6
	4,250	122.8	122.8	6.4	118.2	118.2	7.3	113.2	113.2	8.3	107.4	107.4	9.4	100.5	100.5	10.6
	6,371	129.4	129.4	6.4	124.4	124.4	7.3	118.9	118.9	8.3	112.7	112.7	9.4	105.3	105.3	10.6
115	5,000	150.0	150.0	8.3	143.6	143.6	9.4	136.8	136.8	10.7	129.2	129.2	12.2	121.2	121.2	14.0
	5,500	152.1	152.1	8.3	145.5	145.5	9.4	138.5	138.5	10.8	130.8	130.8	12.3	122.6	122.6	14.0
	8,495	160.0	160.0	8.4	152.8	152.8	9.6	145.2	145.2	10.8	137.0	137.0	12.4	128.1	128.1	14.1
145	6,200	171.0	171.0	9.4	163.7	163.7	10.5	155.7	155.7	11.8	147.1	147.1	13.2	138.2	138.2	14.9
	6,800	173.2	173.2	9.4	165.7	165.7	10.5	157.5	157.5	11.8	148.8	148.8	13.3	139.7	139.7	14.9
	10,533	182.0	182.0	9.6	173.8	173.8	10.7	165.0	165.0	12.0	155.8	155.8	13.4	148.7	148.7	14.9
175	7,700	226.1	226.1	12.3	216.7	216.7	13.7	207.1	207.1	15.2	196.9	196.9	17.0	185.7	185.7	19.1
	8,500	229.4	229.4	12.3	219.7	219.7	13.7	210.0	210.0	15.3	199.4	199.4	17.1	188.1	188.1	19.1
	13,082	241.6	241.6	12.4	231.1	231.1	13.8	220.4	220.4	15.4	208.8	208.8	17.2	196.7	196.7	19.2
200	9,000	300.1	300.1	16.9	287.3	287.3	19.0	272.7	272.7	21.4	257.0	257.0	24.1	239.5	239.5	27.2
	10,000	304.7	304.7	17.0	291.6	291.6	19.0	276.7	276.7	21.5	260.5	260.5	24.2	242.6	242.6	27.3
	15,291	320.1	320.1	17.2	306.0	306.0	19.3	290.2	290.2	21.7	272.5	272.5	24.5	257.4	257.4	27.3
250	10,000	322.6	322.6	19.6	308.3	308.3	21.8	292.5	292.5	24.4	276.0	276.0	27.3	258.1	258.1	30.5
	11,000	326.9	326.9	19.6	312.3	312.3	21.8	296.1	296.1	24.5	279.3	279.3	27.4	261.0	261.0	30.6
	16,990	343.7	343.7	19.9	327.7	327.7	22.2	310.1	310.1	24.8	291.9	291.9	27.7	272.0	272.0	31.0

Legend

AFR : Air Flow Rate
T.CAP : Total Cooling Capacity
S.CAP : Sensible Cooling Capacity
PI : Power input

Note

- Performance data are calculated based on 85/64.4°F entering dry bulb/ entering wet bulb temperature
- Power input in this page should not be used for cable or breaker selection. MCA and MOP values in the electrical data section should be referred for the same

Refrigeration Schematic Diagram



PASC4 45-1 , 55-1 , 85-2 , 115-2

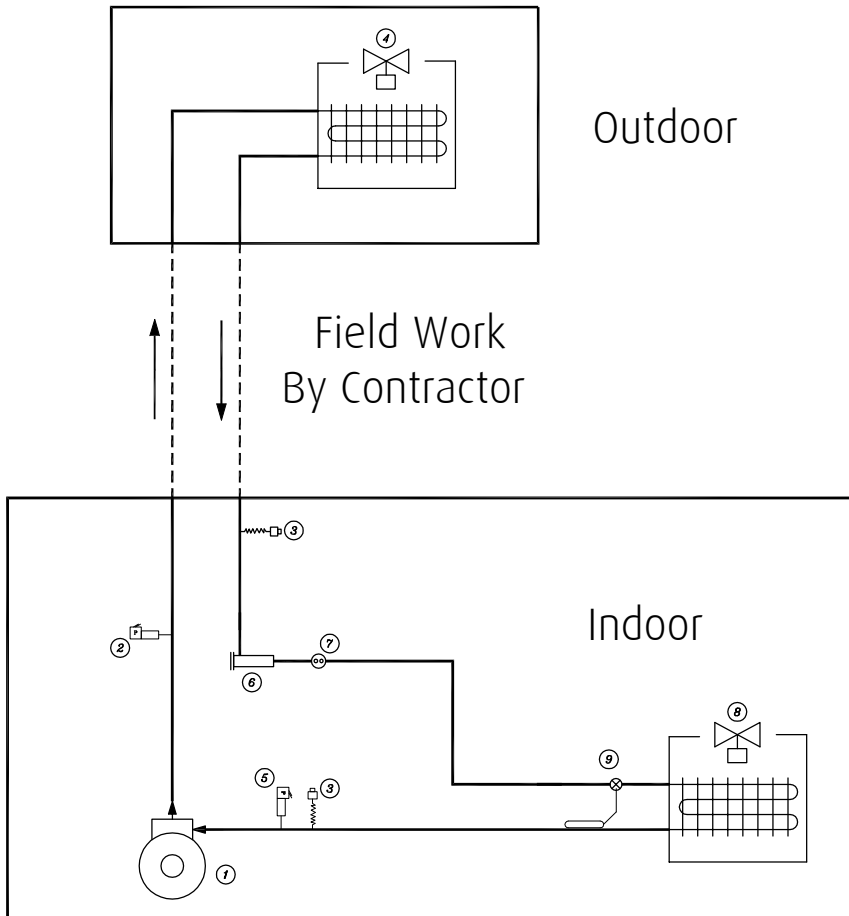

	Item
1	Hermetic Compressor
2	High Pressure Switch
3	Charging Nipple
4	Condenser Coil & fan
5	Low Pressure Switch
6	Filter Drier
7	Sight Glass
8	Evaporator Coil & fan
9	Expansion Valve

PASC4 145-2 , 175-2 , 200-2 , 250-2

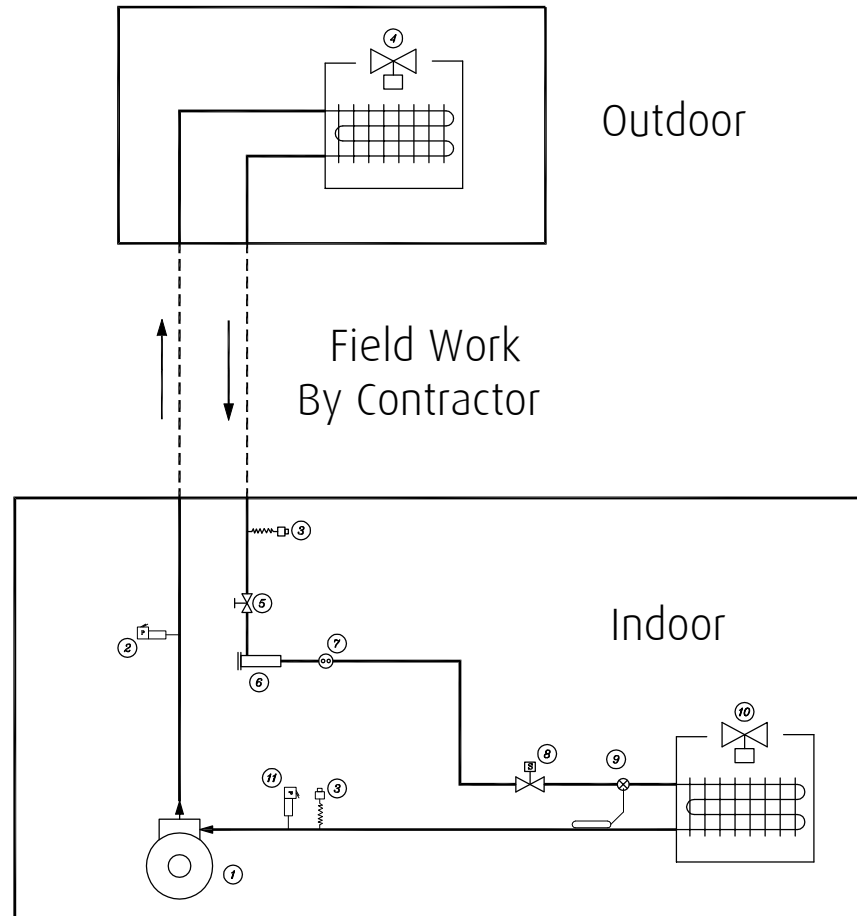

	Item
1	Hermetic Compressor
2	High Pressure Switch
3	Charging Nipple
4	Condenser Coil & fan
5	Shut off Valve
6	Filter Drier
7	Sight Glass
8	Solenoid Valve
9	Expansion Valve
10	Evaporator Coil & fan
11	Low Pressure Switch

Electrical Data



PASC4	POWER SUPPLY	SUPPLIED VOLTAGE		COMPRESSOR			CONDENSOR FAN MOTOR			EVAPORATOR FAN MOTOR			S.H.C	E. HEATER		MCA	MOP	MDS
	[V/Ph/Hz]	MIN	MAX	No.	RLA	LRA (A)	No.	kW	FLA (A)	No.	kW	FLA (A)	(A)	STG.	kW			
45-1	380-420/3/50	357	440	1	7.6	52	1	0.5	1.1	1	1.9	2.9	3	1	3	18.0	25	25
	380/3/60	357	403	1	8.9	66	1	0.7	1.2	1	1.9	2.9	3	1	3	19.8	25	25
	460/3/60	432	488	1	7.9	52	1	0.8	1.3	1	1.9	2.9	3	1	3	17.8	25	25
55-1	380-420/3/50	357	440	1	10.9	64	1	0.5	1.1	1	1.9	2.9	3	1	3	22.1	30	25
	380/3/60	357	403	1	11.9	78	1	0.7	1.2	1	1.9	2.9	3	1	3	23.5	35	25
	460/3/60	432	488	1	10.9	62	1	0.8	1.3	1	1.9	2.9	3	1	3	21.5	30	25
85-2	380-420/3/50	357	440	2	7.6	52	1	0.5	1.1	1	1.9	2.9	5	1	6	30.5	35	40
	380/3/60	357	403	2	8.9	66	1	0.7	1.2	1	1.9	2.9	5	1	6	33.3	40	40
	460/3/60	432	488	2	7.9	52	1	0.8	1.3	1	1.9	2.9	5	1	6	29.5	35	40
115-2	380-420/3/50	357	440	2	10.9	64	2	0.5	1.1	1	2.7	4.2	8	1	7.5	42.3	50	60
	380/3/60	357	403	2	11.9	78	2	0.7	1.2	1	2.7	4.2	8	1	7.5	44.7	50	60
	460/3/60	432	488	2	10.9	62	2	0.8	1.3	1	2.7	4.2	8	1	7.5	40.6	50	60
145-2	380-420/3/50	357	440	2	11.8	74	2	0.5	1.1	2	1.9	2.9	10	1	9	48.6	60	60
	380/3/60	357	403	2	12.2	75	2	0.7	1.2	2	1.9	2.9	10	1	9	49.6	60	60
	460/3/60	432	488	2	11.9	88	2	0.8	1.3	2	1.9	2.9	10	1	9	46.4	50	60
175-2	380-420/3/50	357	440	2	16.4	95	3	0.5	1.1	2	2.7	4.2	10	1	9	61.1	70	80
	380/3/60	357	403	2	18.6	123	3	0.7	1.2	2	2.7	4.2	10	1	9	66.3	80	80
	460/3/60	432	488	2	16.4	95	3	0.8	1.3	2	2.7	4.2	10	1	9	59.1	70	80
200-2	380-420/3/50	357	440	2	20.0	118	3	0.5	1.1	2	2.7	4.2	15	1	12	74.8	90	100
	380/3/60	357	403	2	26.4	125	3	0.7	1.2	2	2.7	4.2	15	1	12	89.6	110	100
	460/3/60	432	488	2	20.0	145	3	0.8	1.3	2	2.7	4.2	15	1	12	72.2	90	80
250-2	380-420/3/50	357	440	2	20.7	118	3	0.5	1.1	2	2.7	4.2	15	1	12	76.4	90	100
	380/3/60	357	403	2	26.4	125	3	0.7	1.2	2	2.7	4.2	15	1	12	89.6	110	100
	460/3/60	432	488	2	20.7	145	3	0.8	1.3	2	2.7	4.2	15	1	12	73.8	90	80

Legend

- RLA: Rated Load Ampere
- LRA: Locked Rotor Ampere
- FLA: Full Load Ampere (for each Fan motor)
- MCA: Minimum Circuit Ampacity
- MOP: Maximum Overcurrent Protection
- MDS: Non-Fused Main Disconnect Switch
- SHC: Steam Humidifier Current

Note

- MCA is based on %125 of the RLA for the largest motor plus %100 of the RLA/FLA for all other loads included in the circuit (NEC-Article 24-430)
- MOP is based on %225 of the RLA for the largest motor plus %100 of the RLA for all other loads included in the circuit (NEC-Article 22-440)
- MDS is based on %115 of the total summation of RLA/FLA for all loads included in the circuit (NEC-Article 12 -440A1)

THIS PAGE INTENTINALLY LEFT BLANK.

Wiring Diagram - 50 Hz



(PASC4 45-1 ~ 85-2)

Control Diagram

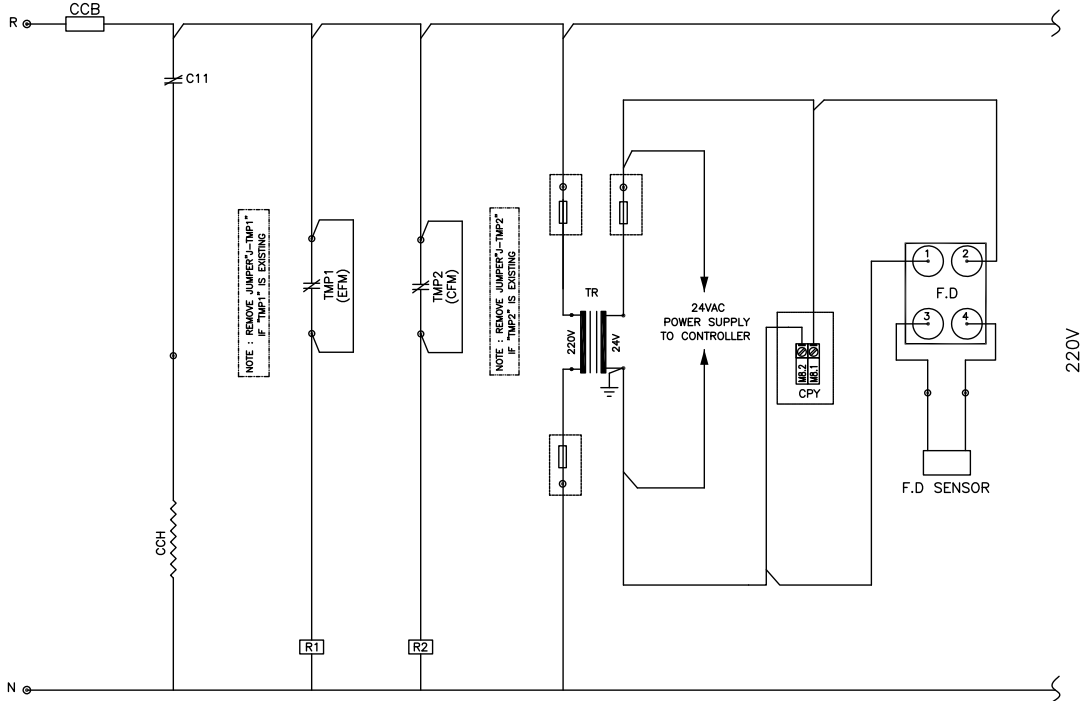

Control Diagram

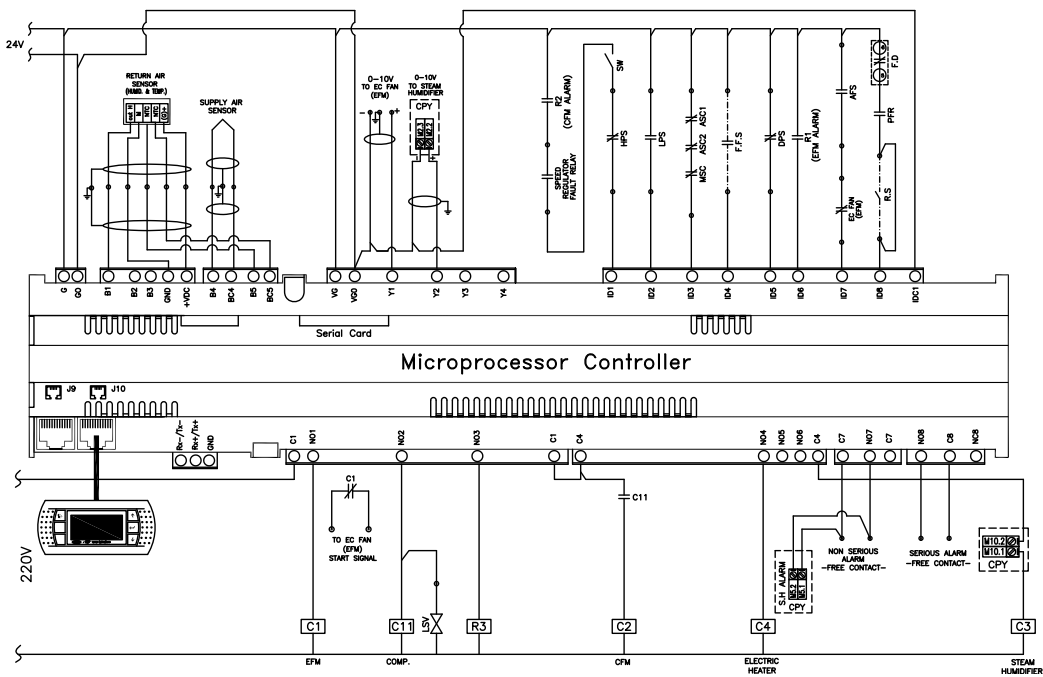

(PASC4 45-1 ~ 85-2)

S.H Control Diagram

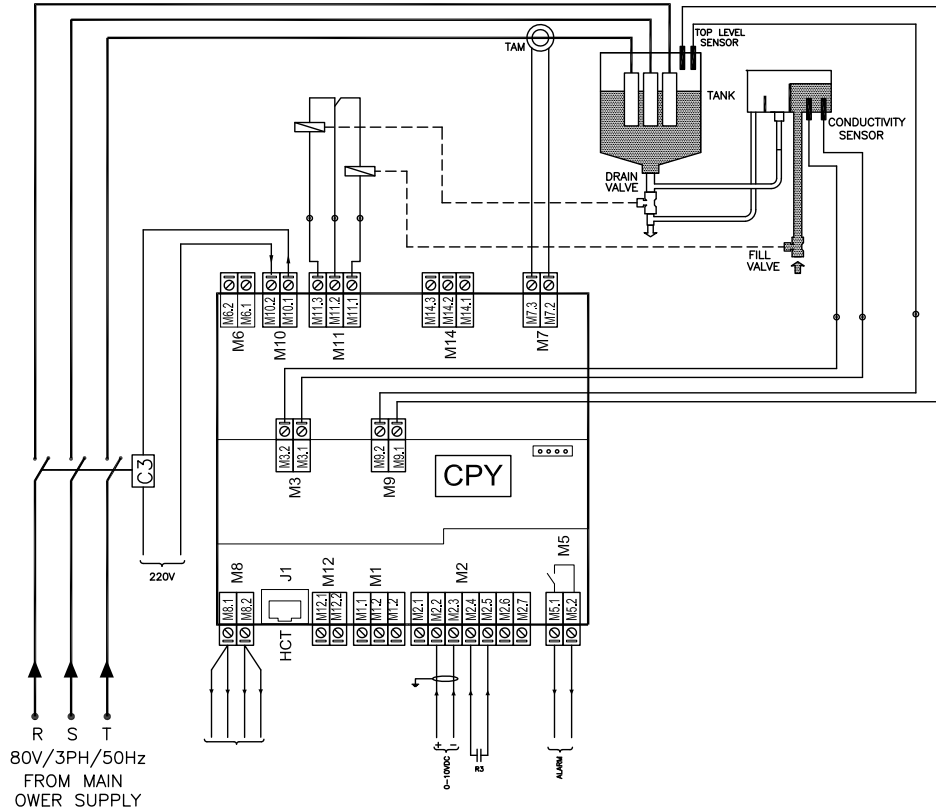

Speed Regulator

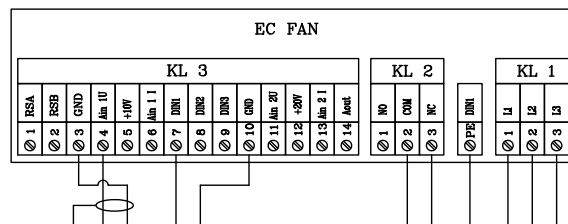
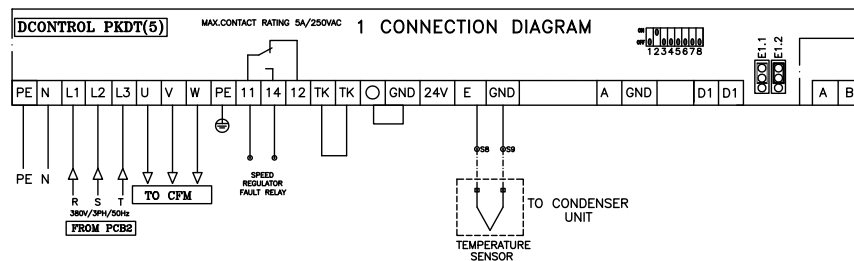

Wiring Diagram - 50 Hz



(PASC4 45-1 ~ 85-2)

Power Diagram

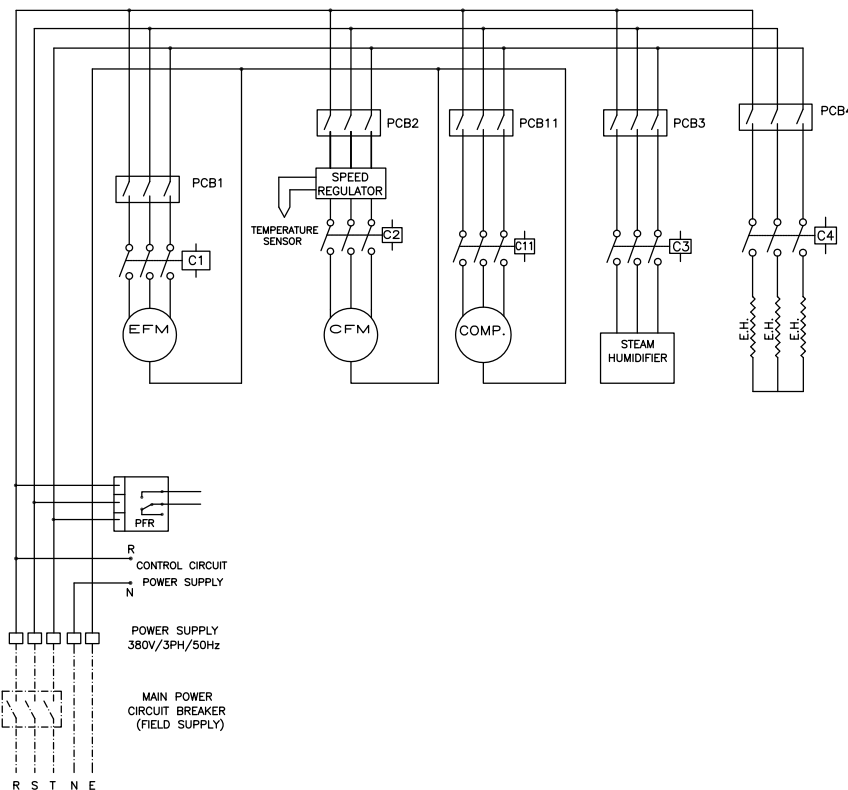

Lists & Tables

LEGEND			
C	CONTACTOR	AFS	AIR FLOW SWITCH
PFR	PHASE FAILURE RELAY	MSC	MANUAL SAFETY CUTOUT
CCH	CRANK CASE HEATER	ASC	AUTOMATIC SAFETY CUTOUT
CCB	CONTROL CIRCUIT BREAKER	F.D	FLOODING DETECTOR
COMP	COMPRESSOR	TAM	CURRENT COIL FOR HUMIDIFIER
CFM	CONDENSER FAN MOTOR	F.F.S	FIRE FIGHTING SYSTEM SWITCH
TR	CONTROL TRANSFORMER	DPS	DEFERENTIAL PRESSURE SWITCH
LPS	LOW PRESSURE SWITCH	J	JUMPER
HPS	HIGH PRESSURE SWITCH	R.S	REMOTE SWITCH
TMP	THERMAL MOTOR PROTECTOR	PCB	POWER CIRCUIT BREAKER
R.S	REMOTE SWITCH	LSV	LIQUID SOLENOID VALVE
EFM	EVAPORATOR FAN MOTOR	①n	TERMINAL NO.
SW	ON/OFF SWITCH	Wn	WIRE NO.
R	CONTROL RELAY	-----	CONNECTION BY OTHERS

PHASE FAILURE TROUBLESHOOTING			
SUPPLY FAULT	GREEN LED	RED LED	
AFTER POWER APPLIED/FAULT CLEARED	ON	FLASHING	
PHASE MISSING	ON	OFF	
PHASE REVERSED (NO DELAY)	FLASHING	OFF	
UNDER OR OVER VOLTAGE CONDITION (DURING DELAY T)	ON	ON FOR DELAY (T)	
UNDER OR OVER VOLTAGE CONDITION (AFTER DELAY T)	OFF	OFF	
PHASE BELOW 70% OF UN (FIXED UNDER TRIP LEVEL (Z))	ON	OFF	

ERROR CONDITION

- 1 * ANY ABNORMAL CONDITION COULD HAPPENED THE CONTROLLER WILL AUTOMATICALLY SWITCH OFF THE CONCERNED CIRCUIT OR THE WHOLE UNIT DEPENDING ON ALARM TYPE, THEN IT WILL GIVE ALARM MESSAGE AND THE CONTROLLER WILL ENERGIZE THE GENERAL ALARM RELAY.
- 2 * IF THIS CONDITION HAPPENED, PUSH THE ALARM BUTTON TO DISPLAY THE ALARM MESSAGE.
- 3 * AFTER FIXING THE ALARM, TO RESET THE ALARM PUSH ALARM BUTTON AGAIN.
- 4 * IN CASE OF AFS CHECK-- EC FAN.

ACCESS TO SET POINT

PRESS PROG. BUTTON **[Prg]** ON THE WALL KEYPAD
 SELECT THE (SETPPOINT) BY PRESSING **[↑]** AND **[↓]** AND THEN PRESS ENTER **[↵]**
 AND THEN PRESS **[←]** TO ENABLE MODIFYING THE VALUE OF TEMP. AND HUMIDITY
 NOW YOU CAN CHANGE IT BY PRESSING **[↑]** AND **[↓]** AND THEN PRESS **[↵]** TO SAVE
 THEN PRESS **[ESC]** TO EXIT TO THE MAIN MENU

(PASC4 115-2 ~ 250-2)

Control Diagram

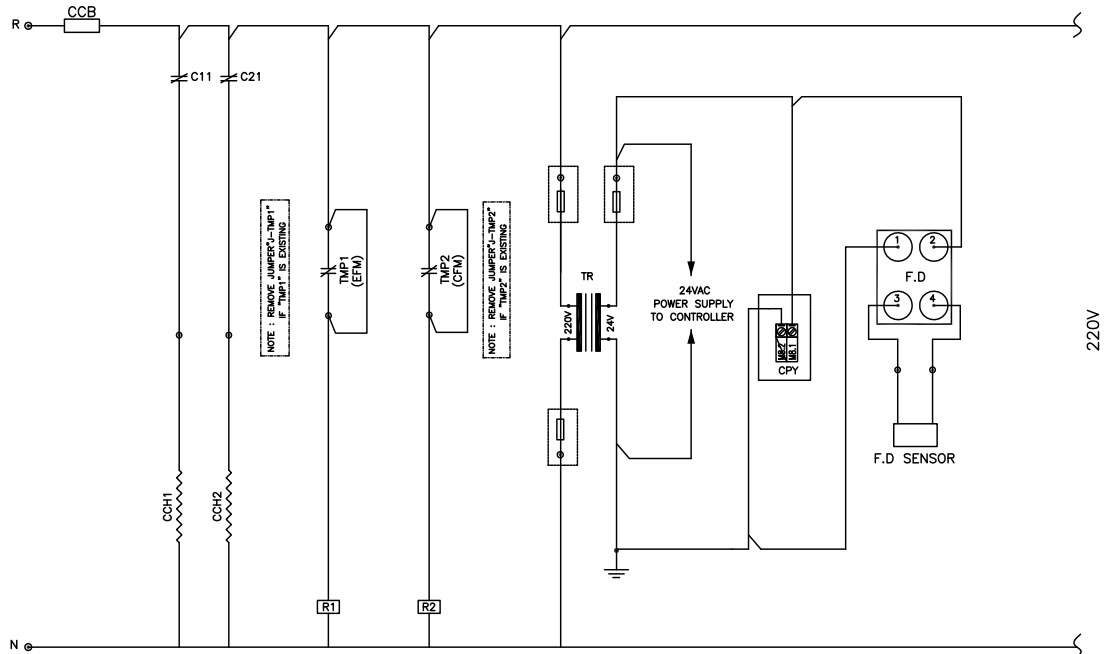

Control Diagram

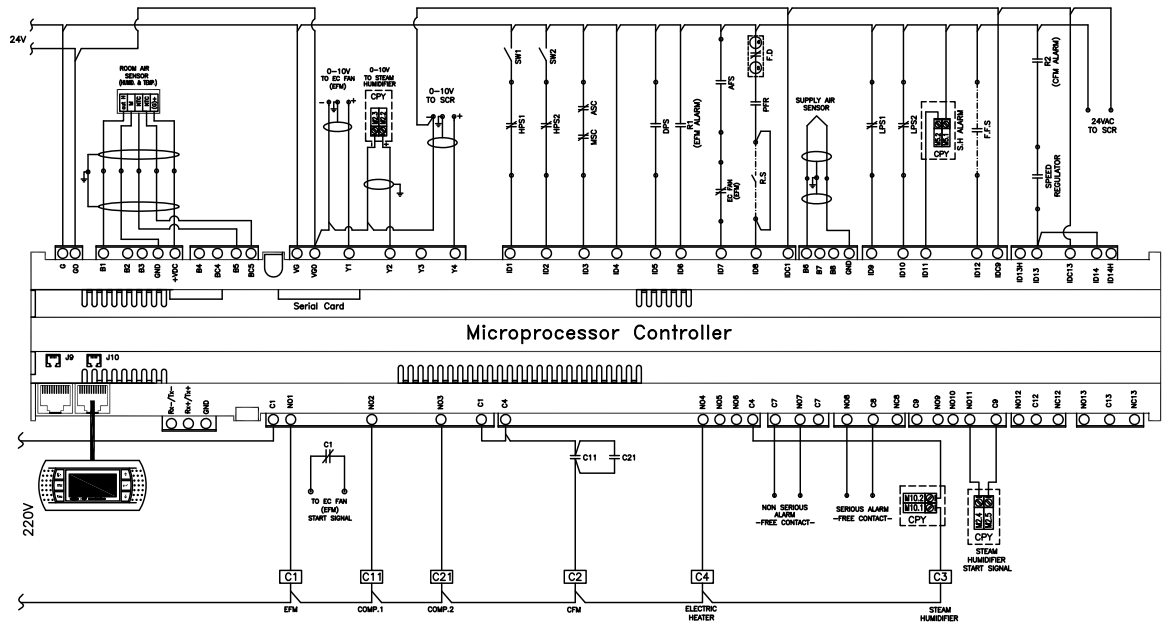

Wiring Diagram - 50 Hz



(PASC4 115-2 ~ 250-2)

S.H Control Diagram

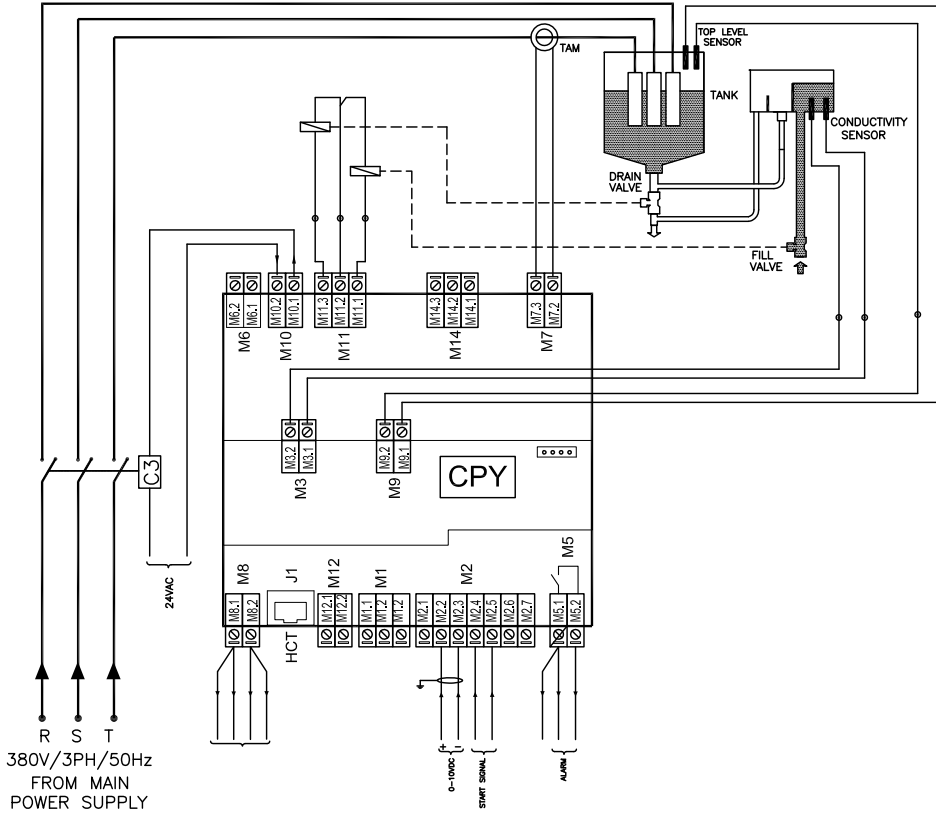

Speed Regulator

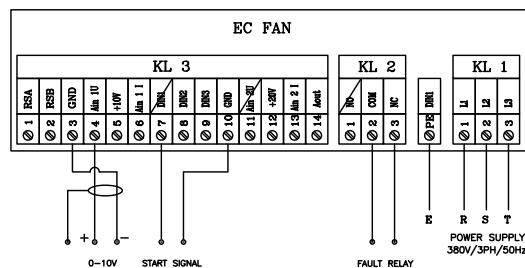
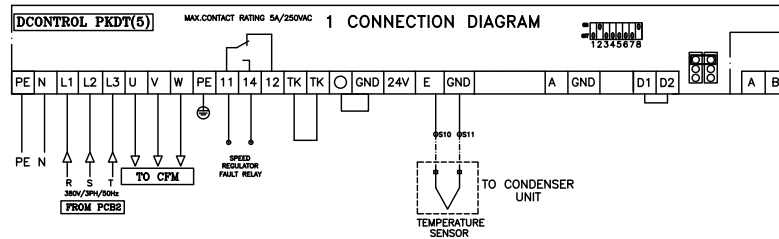
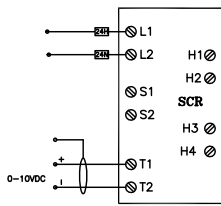

(PASC4 115-2 ~ 250-2)

Power Diagram

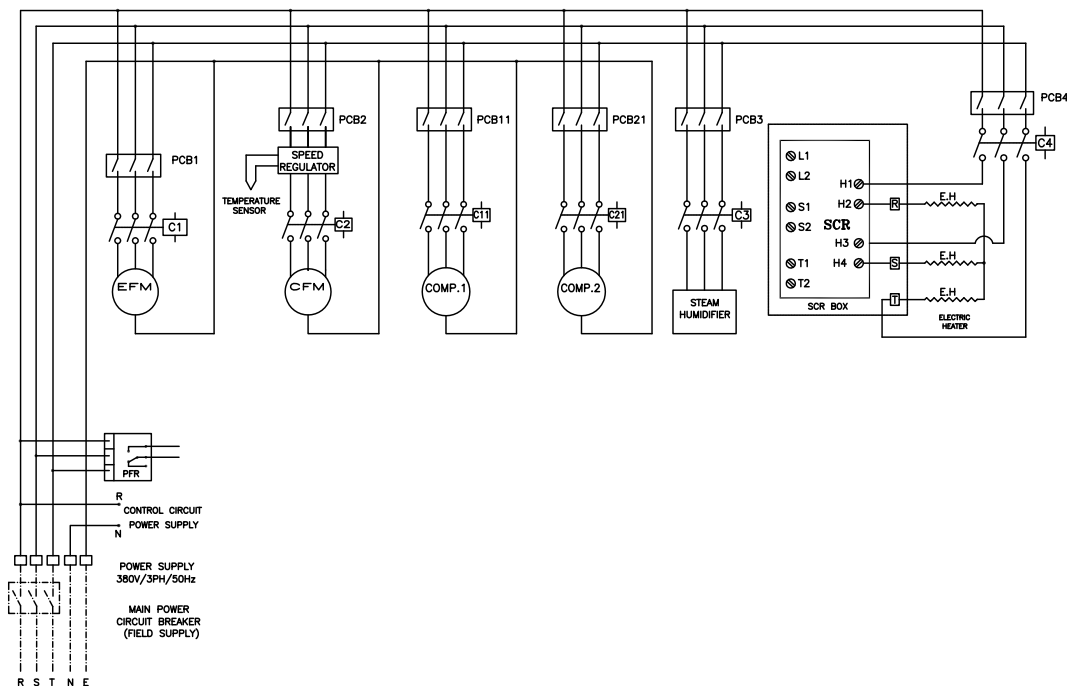

Lists & Tables

LEGEND			
C	CONTACTOR	AFS	AIR FLOW SWITCH
PFR	PHASE FAILURE RELAY	MSC	MANUAL SAFETY CUTOFF
CCH	CRANK CASE HEATER	ASC	AUTOMATIC SAFETY CUTOFF
CCB	CONTROL CIRCUIT BREAKER	F.D	FLOODING DETECTOR
COMP	COMPRESSOR	TAM	CURRENT COIL FOR HUMIDIFIER
CFM	CONDENSER FAN MOTOR	F.F.S	FIRE FIGHTING SYSTEM SWITCH
TR	CONTROL TRANSFORMER	DPS	DIFFERENTIAL PRESSURE SWITCH
LPS	LOW PRESSURE SWITCH	J	JUMPER
HPS	HIGH PRESSURE SWITCH	R.S	REMOTE SWITCH
TMP	THERMAL MOTOR PROTECTOR	PCB	POWER CIRCUIT BREAKER
R.S	REMOTE SWITCH	SCR	SILICON CONTROLLED RECTIFIER
EFM	EVAPORATOR FAN MOTOR	@n	TERMINAL NO.
SW	ON/OFF SWITCH	W _n	WIRE NO.
R	CONTROL RELAY	-----	CONNECTION BY OTHERS

PHASE FAILURE TROUBLESHOOTING		
SUPPLY FAULT	GREEN LED	RED LED
AFTER POWER APPLIED/FAULT CLEARED	ON	FLASHING
PHASE MISSING	ON	OFF
PHASE REVERSED (NO DELAY)	FLASHING	OFF
UNDER OR OVER VOLTAGE CONDITION (DURING DELAY T)	ON	ON FOR DELAY (T)
UNDER OR OVER VOLTAGE CONDITION (AFTER DELAY T)	ON	OFF
PHASE BELOW 70% OF UN (FIXED UNDER TRIP LEVEL [2])	ON	OFF

ERROR CONDITION

- 1 * ANY ABNORMAL CONDITION COULD HAPPENED THE CONTROLLER WILL AUTOMATICALLY SWITCH OFF THE CONCERNED CIRCUIT OR THE WHOLE UNIT DEPENDING ON ALARM TYPE, THEN IT WILL GIVE ALARM MESSAGE AND THE CONTROLLER WILL ENERGIZE THE GENERAL ALARM RELAY.
- 2 * IF THIS CONDITION HAPPENED, PUSH THE ALARM BUTTON TO DISPLAY THE ALARM MESSAGE.
- 3 * AFTER FIXING THE ALARM, TO RESET THE ALARM PUSH ALARM BUTTON AGAIN.
- 4 * IN CASE OF "OVERLOAD OR HP PRESSOSTAT COMPRESSOR 1/2" MESSAGE CHECK :- HPS, SW

ACCESS TO SET POINT

PRESS PROG. BUTTON (P₁₉) ON THE WALL KEYPAD
 SELECT THE (SETPOINT) BY PRESSING (↑) AND (↓) AND THEN PRESS ENTER (↵)
 AND THEN PRESS (←) TO ENABLE MODIFYING THE VALUE OF TEMP. AND HUMIDITY
 NOW YOU CAN CHANGE IT BY PRESSING (↑) AND (↓) AND THEN PRESS (←) TO SAVE
 THEN PRESS (ESC) TO EXIT TO THE MAIN MENU

Wiring Diagram - 60 Hz



(PASC4 45-1 ~ 85-2)

Control Diagram

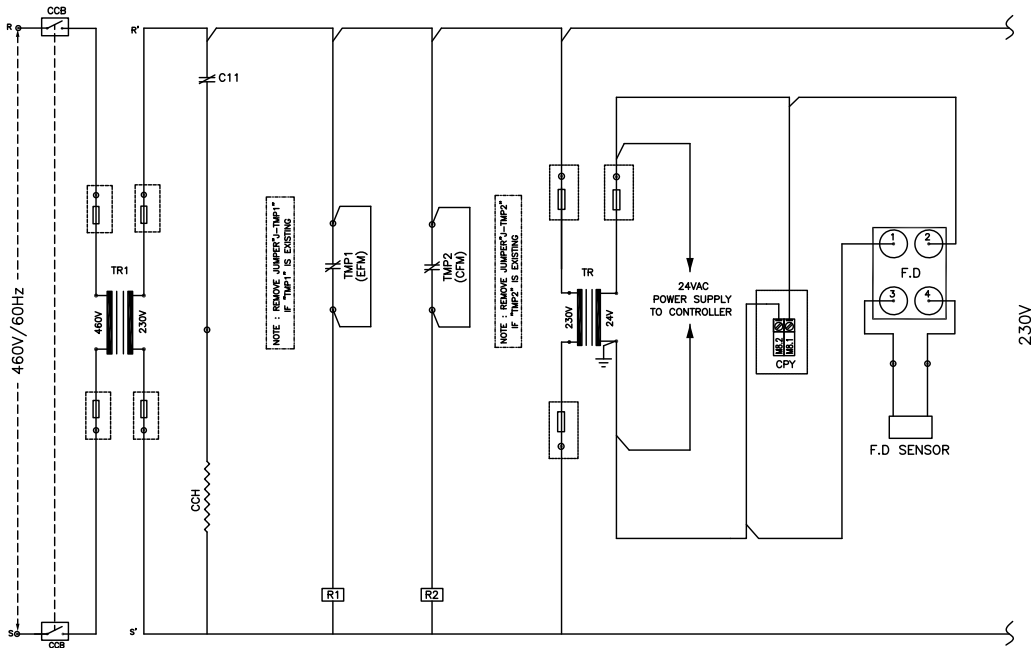

Control Diagram

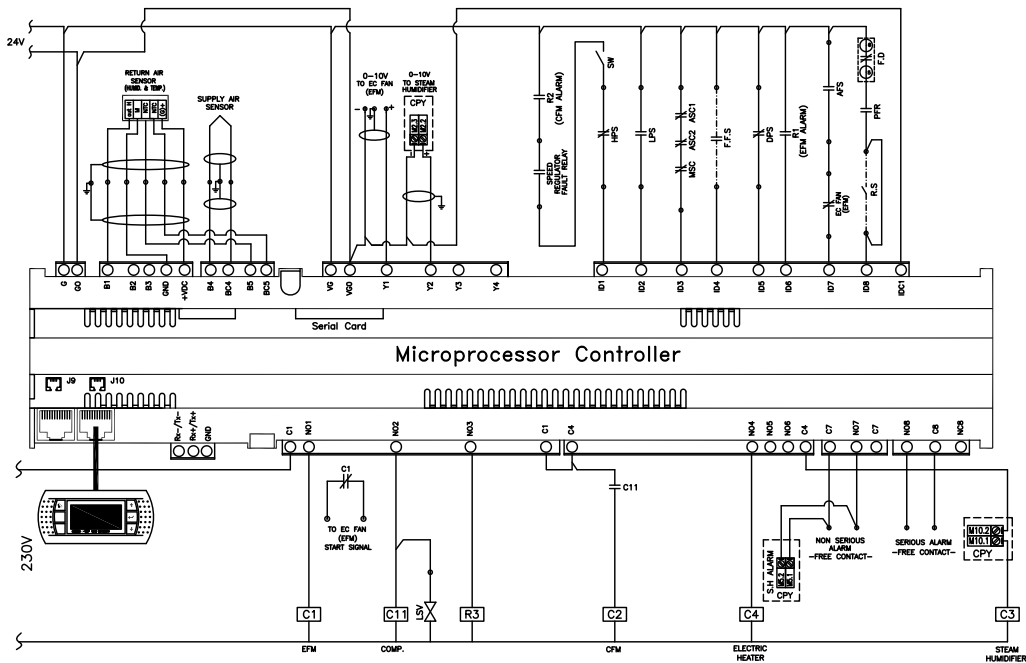

(PASC4 45-1 ~ 85-2)

S.H Control Diagram

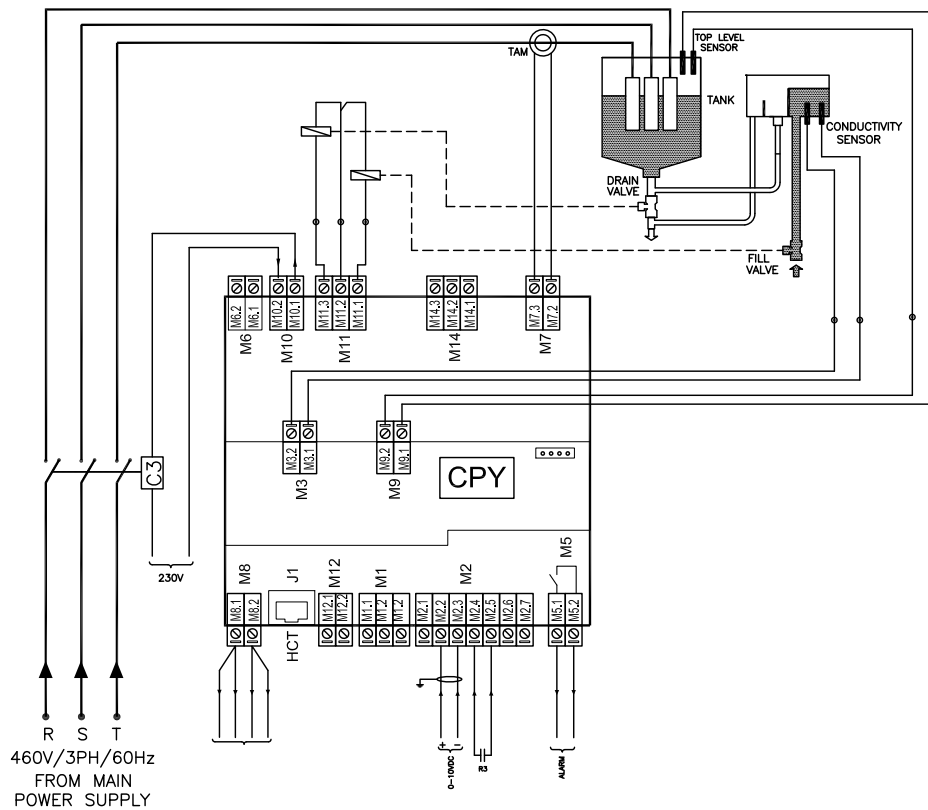

Speed Regulator

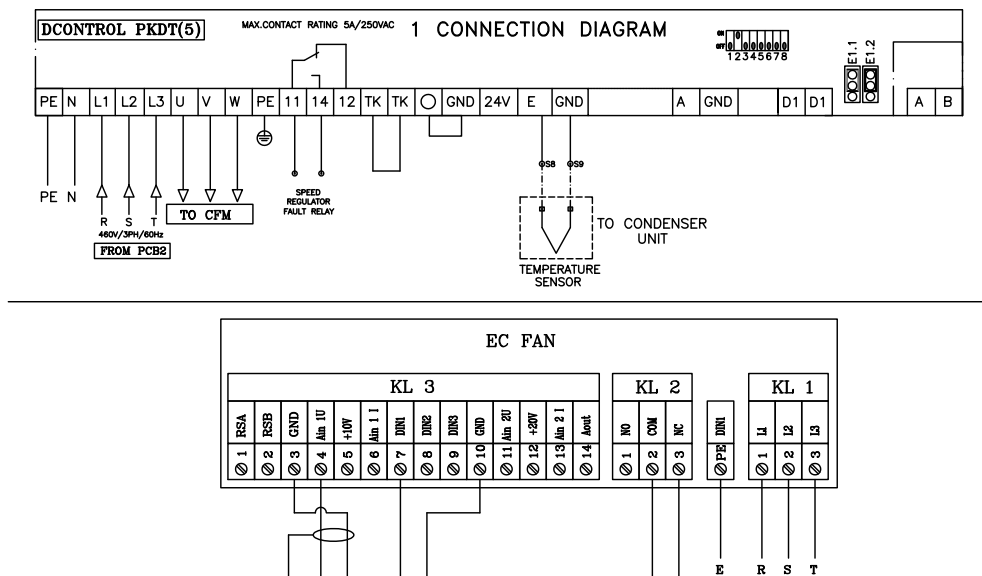

Wiring Diagram - 60 Hz



(PASC4 45-1 ~ 85-2)

Power Diagram

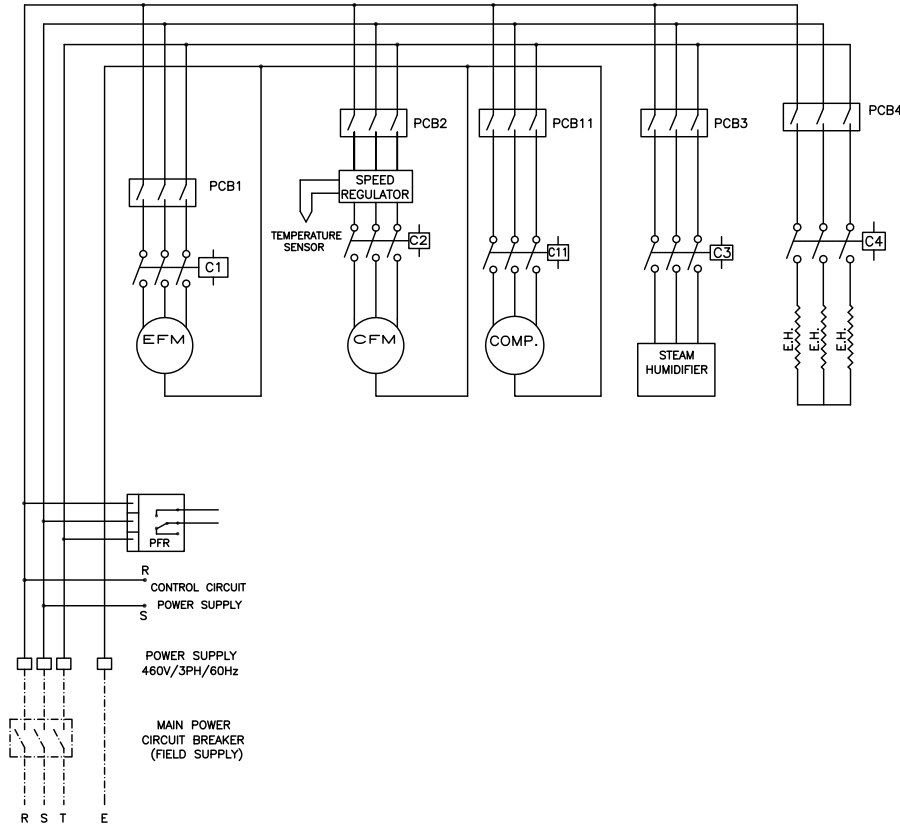

Lists & Tables

LEGEND			
C	CONTACTOR	AFS	AIR FLOW SWITCH
PFR	PHASE FAILURE RELAY	MSC	MANUAL SAFETY CUTOFF
CCH	CRANK CASE HEATER	ASC	AUTOMATIC SAFETY CUTOFF
CCB	CONTROL CIRCUIT BREAKER	F.D	FLOODING DETECTOR
COMP	COMPRESSOR	TAM	CURRENT COIL FOR HUMIDIFIER
CFM	CONDENSER FAN MOTOR	F.F.S	FIRE FIGHTING SYSTEM SWITCH
TR	CONTROL TRANSFORMER	DPS	DEFERENTIAL PRESSURE SWITCH
LPS	LOW PRESSURE SWITCH	J	JUMPER
HPS	HIGH PRESSURE SWITCH	R.S	REMOTE SWITCH
TMP	THERMAL MOTOR PROTECTOR	PCB	POWER CIRCUIT BREAKER
R.S	REMOTE SWITCH	LSV	LIQUID SOLENOID VALVE
EFM	EVAPORATOR FAN MOTOR	⊙ _n	TERMINAL NO.
SW	ON/OFF SWITCH	W _n	WIRE NO.
R	CONTROL RELAY	--- ---	CONNECTION BY OTHERS

ERROR CONDITION
1 * ANY ABNORMAL CONDITION COULD HAPPENED THE CONTROLLER WILL AUTOMATICALLY SWITCH OFF THE CONCERNED CIRCUIT OR THE WHOLE UNIT DEPENDING ON ALARM TYPE, THEN IT WILL GIVE ALARM MESSAGE AND THE CONTROLLER WILL ENERGIZE THE GENERAL ALARM RELAY.
2 * IF THIS CONDITION HAPPENED, PUSH THE ALARM BUTTON TO DISPLAY THE ALARM MESSAGE.
3 * AFTER FIXING THE ALARM, TO RESET THE ALARM PUSH ALARM BUTTON AGAIN.
4 * IN CASE OF AFS CHECK:- EC FAN.

PFR INDICATOR LIGHT DIAGNOSTICS	
RUN	GREEN
RESTART DELAY	GREEN
REVERSE PHASE	RED
UNBALANCE/SINGLE PHASE	RED
HIGH/LOW VOLTAGE	RED

ACCESS TO SET POINT
PRESS PROG. BUTTON (Prog) ON THE WALL KEYPAD
SELECT THE (SETPOINT) BY PRESSING (↑) AND (↓) AND THEN PRESS ENTER (↵)
AND THEN PRESS (←) TO ENABLE MODIFYING THE VALUE OF TEMP. AND HUMIDITY
NOW YOU CAN CHANGE IT BY PRESSING (↑) AND (↓) AND THEN PRESS (↵) TO SAVE
THEN PRESS (Esc) TO EXIT TO THE MAIN MENU

Wiring Diagram - 60 Hz



(PASC4 115-2 ~ 250-2)

S.H Control Diagram

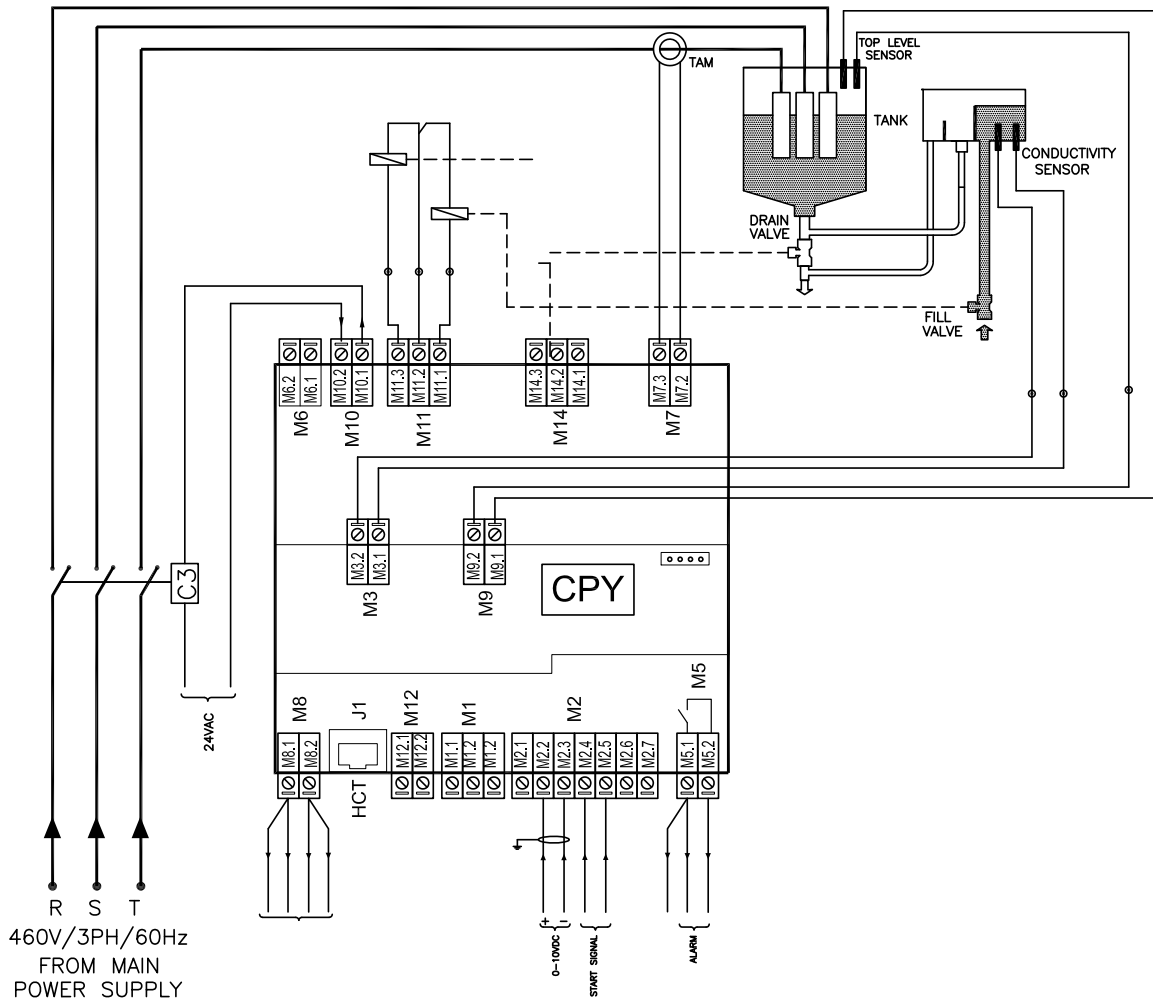

(PASC4 115-2 ~ 250-2)

Power Diagram

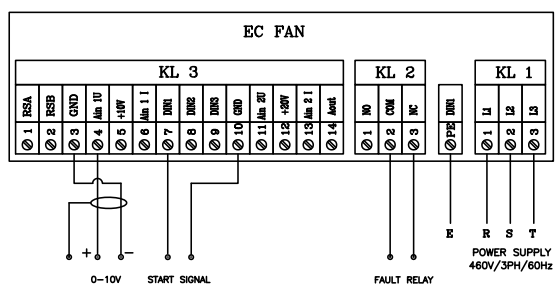
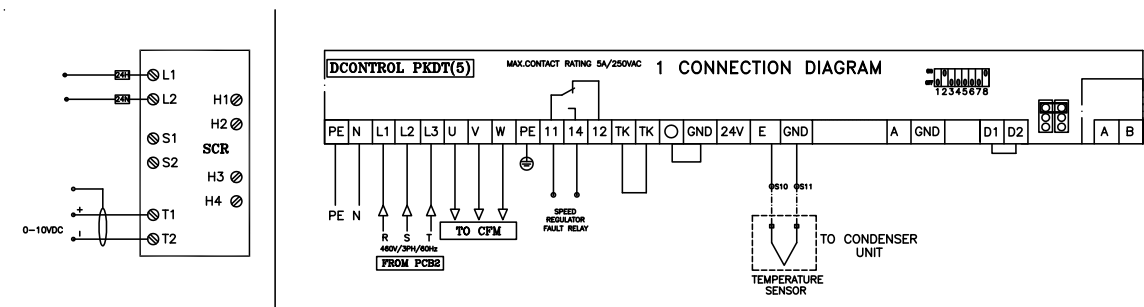

Power Diagram

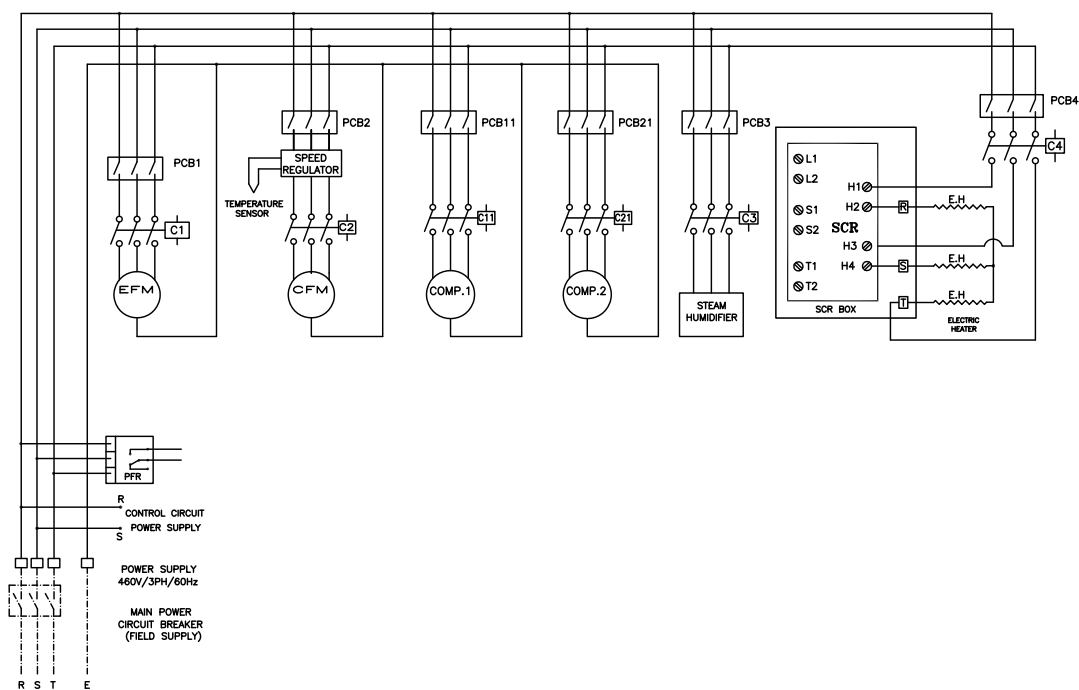



Wiring Diagram - 60 Hz



(PASC4 115-2 ~ 250-2)

Lists & Tables

LEGEND			
C	CONTACTOR	AFS	AIR FLOW SWITCH
PFR	PHASE FAILURE RELAY	MSC	MANUAL SAFETY CUTOFF
CCH	CRANK CASE HEATER	ASC	AUTOMATIC SAFETY CUTOFF
CCB	CONTROL CIRCUIT BREAKER	F.D	FLOODING DETECTOR
COMP	COMPRESSOR	TAM	CURRENT COIL FOR HUMIDIFIER
CFM	CONDENSER FAN MOTOR	F.F.S	FIRE FIGHTING SYSTEM SWITCH
TR	CONTROL TRANSFORMER	DPS	DEFERENTIAL PRESSURE SWITCH
LPS	LOW PRESSURE SWITCH	J	JUMPER
HPS	HIGH PRESSURE SWITCH	R.S	REMOTE SWITCH
TMP	THERMAL MOTOR PROTECTOR	PCB	POWER CIRCUIT BREAKER
R.S	REMOTE SWITCH	SCR	SILICON CONTROLLED RECTIFIER
EFM	EVAPORATOR FAN MOTOR	ϕ _n	TERMINAL NO.
SW	ON/OFF SWITCH	W _n	WIRE NO.
R	CONTROL RELAY	-----	CONNECTION BY OTHERS

PFR INDICATOR LIGHT DIAGNOSTICS	
RUN	GREEN
RESTART DELAY	 GREEN
REVERSE PHASE	 RED
UNBALANCE/SINGLE PHASE	 RED
HIGH/LOW VOLTAGE	RED

ERROR CONDITION

- 1 * ANY ABNORMAL CONDITION COULD HAPPENED THE CONTROLLER WILL AUTOMATICALLY SWITCH OFF THE CONCERNED CIRCUIT OR THE WHOLE UNIT DEPENDING ON ALARM TYPE, THEN IT WILL GIVE ALARM MESSAGE AND THE CONTROLLER WILL ENERGIZE THE GENERAL ALARM RELAY.
- 2 * IF THIS CONDITION HAPPENED, PUSH THE ALARM BUTTON TO DISPLAY THE ALARM MESSAGE.
- 3 * AFTER FIXING THE ALARM, TO RESET THE ALARM PUSH ALARM BUTTON AGAIN.
- 4 * IN CASE OF "OVERLOAD OR HP PRESSOSTAT COMPRESSOR 1/2" MESSAGE CHECK :- HPS,SW

ACCESS TO SET POINT

PRESS PROG. BUTTON (Prog) ON THE WALL KEYPAD
 SELECT THE (SETPOINT) BY PRESSING (↑) AND (↓) AND THEN PRESS ENTER (↵)
 AND THEN PRESS (←) TO ENABLE MODIFYING THE VALUE OF TEMP. AND HUMIDITY
 NOW YOU CAN CHANGE IT BY PRESSING (↑) AND (↓) AND THEN PRESS (←) TO SAVE
 THEN PRESS (Esc) TO EXIT TO THE MAIN MENU